

Manual

# RCA-Bridge

Item- no. 46-01116 | 46-01117



Adapter for  
Tams feedback-bus

tams elektronik



## Table of Contents

1. Getting started.....	3
2. Safety instructions.....	5
3. Operation overview.....	7
4. Technical specifications.....	11
5. Connecting the RCA-Bridge.....	12
6. Setting the address ranges.....	16
7. Check list for troubleshooting.....	17
8. Guarantee bond.....	20
9. EU declaration of conformity.....	21
10. Declarations conforming to the WEEE directive.....	21

© 12/2019 Tams Elektronik GmbH

All rights reserved. No part of this publication may be reproduced or transmitted in any form or by any means, electronic or mechanical, including photocopying, without prior permission in writing from Tams Elektronik GmbH.

Subject to technical modification.

## 1. Getting started

### **Notes on RailCom®**

The RailCom devices described here meet the requirements of the RailCommunity standard proposal RCN-217 "RailCom DCC feedback protocol" (status 18.12.2016). The RCN-217 is published at: [www.railcommunity.org](http://www.railcommunity.org)

RailCom® is a registered German trademark of Lenz Elektronik GmbH. In order to increase the readability of the text, we have refrained from making reference to it whenever the term RailCom is used.

### **Notes on BiDiB®**

The BiDiB devices described in this manual comply with the standards of the BiDiB specification (status V0.7). The BiDiB specification has been published on: [www.bidib.org](http://www.bidib.org).

BiDiB® is a registered trademark. Copyrights and trademarks to BiDiB are held by Wolfgang Kufer, OpenDCC.de.

In order to increase the readability of this text, we have dispensed with referring to this with every use of the term BiDiB.

### **How to use this manual**

This manual gives step-by-step instructions for safe and correct connecting of the adapter, and operation. Before you start, we advise you to read the whole manual, particularly the chapter on safety instructions and the checklist for trouble shooting. You will then know where to take care and how to prevent mistakes which take a lot of effort to correct.

Keep this manual safely so that you can solve problems in the future. If you pass the adapter on to another person, please pass on the manual with it.

## Intended use

The adapter RCA-Bridge is designed to be operated according to the instructions in this manual in digital model railway layouts. Any other use is inappropriate and invalidates any guarantees.

The adapter should not be mounted by children under the age of 14.

Reading, understanding and following the instructions in this manual are mandatory for the user.

## Package contents

- one adapter RCA-Bridge, depending on the model ready-built module, item number 46-01116 or ready-built module in a housing, item number 46-01117
- one 5-pole cable with both-sided plug-in connectors
- one short-circuit jumper
- a CD (containing the manual and further information)

## Required materials

As a power supply you need a power pack (e.g. a.c. power pack item no. 70-09110-01):

Voltage	12 V a.c. voltage or 16 – 18 V d.c. voltage
Current	min. 600 mA
Connection to BiDi-Power	Coaxial power connector (DC power connector) external / internal diameter of the plug: 5.5 / 2.1 mm

Hint: When connecting two or three adapters RCA-Bridge to one Tams feedback-bus, one power pack is sufficient to supply all RCA-Bridges.

## 2. Safety instructions



### **Caution:**

The adapter contains integrated circuits. These are very sensitive to static electricity. Do not touch components without first discharging yourself. Touching a radiator or other grounded metal part will discharge you.

### **Mechanical hazards**

Cut wires can have sharp ends and can cause serious injuries. Watch out for sharp edges when you pick up the PCB.

Visibly damaged parts can cause unpredictable danger. Do not use damaged parts: recycle and replace them with new ones.

### **Electrical hazards**

- Touching powered, live components,
- touching conducting components which are live due to malfunction,
- short circuits and connecting the circuit to another voltage than specified,
- impermissibly high humidity and condensation build up

can cause serious injury due to electrical shock. Take the following precautions to prevent this danger:

- Never perform wiring on a powered module.
- Assembling and mounting the kit should only be done in closed, clean, dry rooms. Beware of humidity.
- Only use low power for this module as described in this manual and only use certified transformers.
- Connect transformers and soldering irons only in approved mains sockets installed by an authorised electrician.
- Observe cable diameter requirements.

- After condensation build up, allow a minimum of 2 hours for dispersion.
- Use only original spare parts if you have to repair the kit or the ready-built module.

### **Other dangers**

Children can cause any of the accidents mentioned above because they are inattentive and not responsible enough. Children under the age of 14 should not be allowed to mount this module.

In schools, training centres, clubs and workshops, assembly must be supervised by qualified personnel.

In industrial institutions, health and safety regulations applying to electronic work must be adhered to.

### 3. Operation overview

The RCA-Bridge allows the transmission of feedback data of RailCom detectors designed for use in BiDiB-systems to RailCom devices communicating via the Tams feedback-bus. The following devices are suitable for use with the RCA-Bridge:

#### **RailCom-detectors** (status 01/2018)

- HERMES of Tams Elektronik (item-no. 46-01086 / 46-01087)
- BiDiB-GBM16TS of Fichtelbahn (item-no. 300250)

Please contact us for information on further RailCom detectors.

#### **Devices for the Tams feedback-bus**

- RailCom-display RCA-1 (item no. 45-02016)
- RailCom-display RCA-24 (item no. 45-02247)
- PC-Interface RC-Link (item no. 45-02257 / 45-02267)

#### **Background information: Tams feedback bus and BiDiBus**

The RailCom standard does not specify how the RailCom messages from the detectors are forwarded, e.g. to PC interfaces or external display devices. Each manufacturer of RailCom components therefore uses its own data bus for data transmission from the detectors to downstream devices.

In 2008 we developed our own data bus (Tams feedback bus) for communication between our RailCom detectors, RailCom display units and RailCom PC interfaces.

This Tams feedback bus formed the basis for the development of the BiDiBus. BiDiB is a manufacturer-independent data protocol that regulates the complete control of all stationary components of a model railway and the transmission of feedback data. This goes far beyond the performance of the Tams feedback bus.

In 2017 we developed HERMES, our first RailCom detector, which transmits the RailCom messages to the PC via the BiDiBus. The connection to the "old" Tams feedback bus can be established using the RCA-Bridge.

### **Integration of the RCA-Bridge into the Tams feedback bus**

The Tams-specific feedback bus for communication between detectors, display devices and PC-Interfaces basically allows

- the supervision of a maximum of 24 separate track sections and
- the connection of a maximum of 32 RailCom-devices (detectors or RCA-Bridges, display devices, PC-Interfaces).

When using RCA-Bridges you have to consider the following particularities:

- It is not possible to connect additional detectors directly to the bus line (e.g. detectors RCD-1, RCD-2 or RCD-8).
- A maximum of 3 RCA-Bridges can be connected to one bus line.
- Each (BiDiB-) RailCom-detector has to be connected via a separate RCA-Bridge. This applies regardless of the number of sections the RailCom-detector can supervise (4, 8 or 16).

### **Setting the addresses**

By inserting jumpers you can set the address ranges for the RCA-Bridge:

1 – 8, 9 – 16 or 17 -24



## Example 1: 3 HERMES + 3 RCA-Bridge + 1 RCA-24

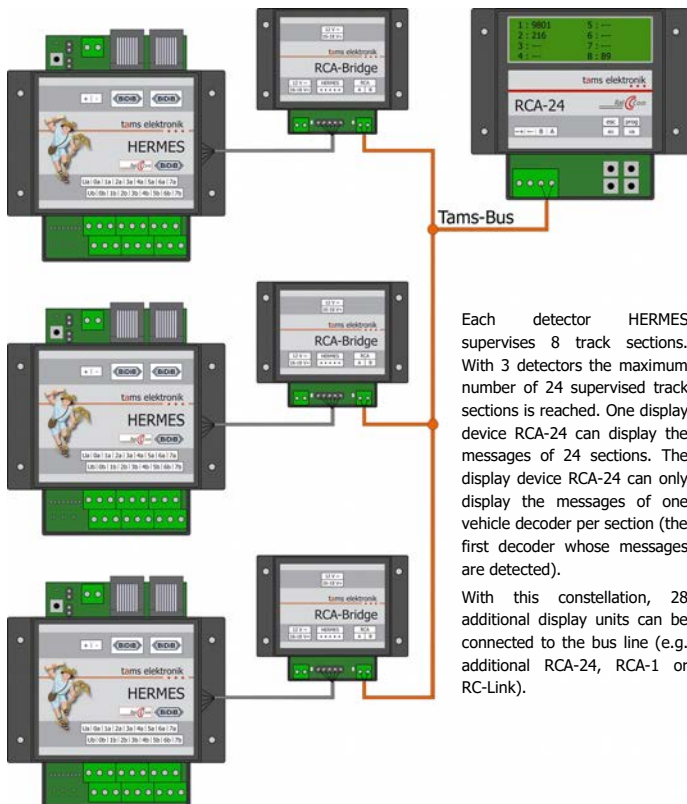

Each detector HERMES supervises 8 track sections. With 3 detectors the maximum number of 24 supervised track sections is reached. One display device RCA-24 can display the messages of 24 sections. The display device RCA-24 can only display the messages of one vehicle decoder per section (the first decoder whose messages are detected).

With this constellation, 28 additional display units can be connected to the bus line (e.g. additional RCA-24, RCA-1 or RC-Link).

## Example 2: 1 HERMES + 1 RCA-Bridge + several RCA-1

You can assign several display devices RCA-1 to each of the 8 track sections supervised by one detector, e.g. in order to display feedback messages at different places of the layout. The RCA-1 can display the messages of 4 decoders in one section one after the other.

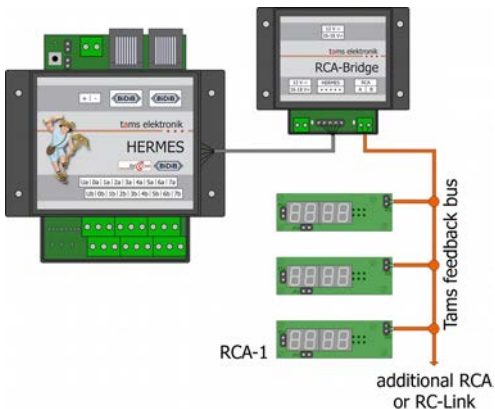

With this constellation (i.e. with one RCA-Bridge in a bus-line), you can connect 31 additional display devices RCA-1. In order to assign a RCA-1 to a track section, you have to program an address between 1 and 24 for the display device (see manual of the display device).

#### 4. Technical specifications

Voltage supply	12 V a.c. voltage or 16 – 18 V d.c. voltage
Connection of supply voltage	Socket for coaxial power connector (DC power connector) external / internal diameter: 5.5 / 2.1 mm
Interface	RCA-Bridge
Protected to	IP 00
Ambient temperature in use	0 ... +60 °C
Ambient temperature in storage	-10 ... +80 °C
Comparative humidity allowed	max. 85 %
Dimensions of the PCB / including housing	approx. 48 x 52 mm approx. 70 x 60 x 25 mm
Weight of the assembled board / including housing	approx. 15 g approx. 32 g

## 5. Connecting the RCA-Bridge

The RCA-Bridge has terminal strips inserted to plug in and screw on the bus line and, if required, a separate power supply. The 5-pole pin-strip is provided for the connection of a RailCom-detector (e.g. HERMES).

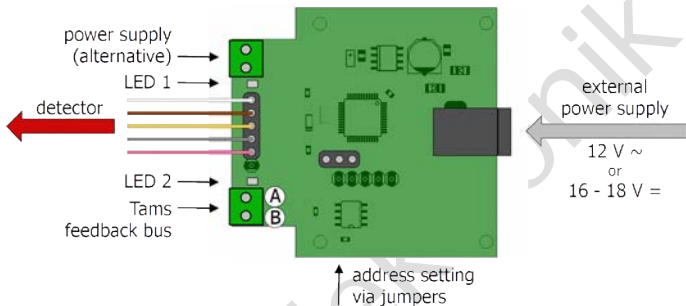

Make the connections one after the other:

- RailCom-detector (e.g. HERMES)
- Tams-feedback bus
- power supply

### Display of the operational readiness

Two LEDs display that the adapter is ready for operation:

- LED 1: Voltage is applied to the adapter.
- LED 2: The adapter receives data from a detector (e.g. HERMES).

## Connecting a RailCom-Detector

You need an extra adapter RCA-Bridge for each RailCom-detector – independent of the number of track sections supervised by the detector (4, 8 or 16). The RailCom-detector must be equipped with an interface for the RCA-Bridge, if not, it cannot be used with the RCA-Bridge.

Most suitable for the connection between detector and RCA-Bridge is the cable included in the package. Ensure to insert the plug-in connectors that way the colours of the cables correspond to the figure below.

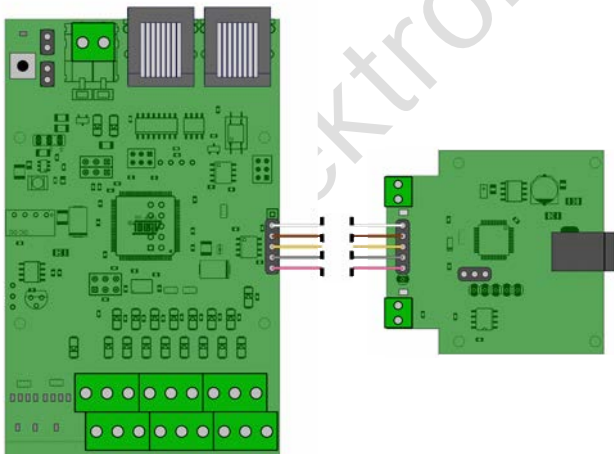

## Connecting RailCom-devices

You can connect the RCA-Bridge via the Tams feedback-bus to display devices (RCA-1 oder RCA-24) and/or the PC-interface (RC-Link) according to your needs.

Observe the following limits for one bus line:

- devices (RCA-Bridge, RCA-1, RCA-24, RC-Link): max. 32
- supervised track sections: max. 24
- adapter RCA-Bridge: max. 3 (this applies to 4-fold detectors as well)

Loop the bus lines A and B through to the other devices. Observe the correct assignment of the lines A and B to the connections A and B of the RailCom-devices.

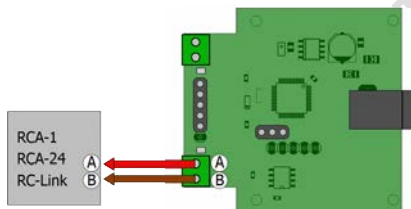

Basically, two cables with a cross section of min. 0,10 mm<sup>2</sup> have to be used as bus lines A and B for the communication between RCA-Bridges, display devices and PC-interfaces. In order to minimise the interference liability of other lines, you should twist the two lines. It is recommended to use special twin cables (e.g. LiYz, 2x0,19 mm<sup>2</sup>, red-brown, item-no. 73-30037).

## Connecting the voltage supply

As a voltage source you can use power packs with

- 12 V a.c. voltage ( $\sim$ ) or
- 16 – 18 V d.c. voltage ( $\equiv$ )

in each case with a current of at least 600 mA.

The connection of the power pack to the RCA-Bridge is made via a coaxial power connector (DC power connector) 5.5 / 2.1 mm.

### ! Attention:

Do not use a power pack with a higher nominal voltage. The resulting surplus power has to be dissipated as heat by the RCA-Bridge. With a too high power, there is a **risk of fire!**

When connecting two or three adapters RCA-Bridge to one Tams feedback-bus, you can supply them together via one power pack. Connect the devices via the connections for the alternative power supply with the other devices. Observe to always connect the "left" and the "right" terminal strips to each other.

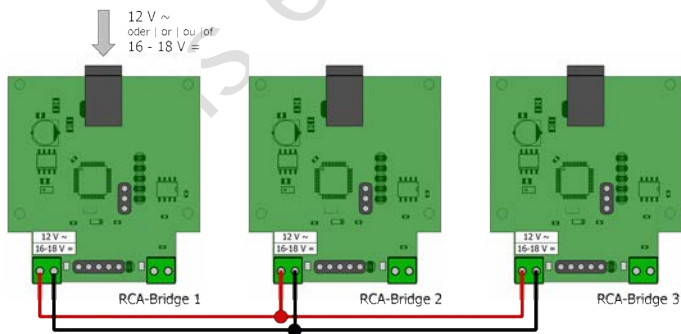

## 6. Setting the address ranges

You assign its address range to the RCA-Bridge by

- inserting no jumper to the 3-pole pin-strip or
- bridging pins 2 and 3 with a jumper or
- bridging pins 1 and 2 with a jumper.

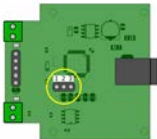
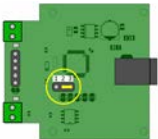
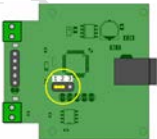
Detector	no jumper	jumper on pin 2 and 3	jumper on pin 1 and 2
			
8-fold (e.g. HERMES)	addresses 1 – 8	addresses 9 – 16	addresses 17 - 24
4-fold	addresses 1 – 4	addresses 9 – 12	addresses 17 - 20
16-fold	addresses 1 – 16	addresses 9 – 24	---
	When connecting a 16-fold detector you always assign 16 consecutive address to the RCA-Bridge. In addition to a 16-fold detector you can connect one more RCA-Bridge to the bus line which transfers the date of one 4- or 8-fold detector.		



## 7. Check list for troubleshooting

- Parts are getting too hot and/or start to smoke.



Disconnect the system from the mains immediately!

Possible cause: The power pack provides a too high voltage.

Possibly the RCA-Bridge and/or other current suppliers connected to the BiDiBus line have been damaged.

- An accessory display device assigned to the RCA-Bridge does not show data.

Possible cause: RCA-Bridge and display device have not been programmed to the same address. → Program the addresses of the two devices anew.

Possible cause: The connection A of the RCA-Bridge is connected to the connection B of the display device (or the other way round). → Exchange the connections A and B at one of the devices.

Possible cause: The booster connected to the controlled rail section is switched off or does not supply the RailCom cutout. → Check the booster.

Possible cause: The vehicle decoder in the supervised rail section does not send a RailCom message, e.g. when in the corresponding CV the RailCom function is set to off. → Check the vehicle decoder.

- LED 1 does not light.

Possible cause: The connection to the power supply has been interrupted. → Check the connections.

Possible cause: The output current of the power pack is too low. → Check the power pack.

- LED 2 does not light.

Possible cause: The RCA-Bridge does not receive data from the connected detector. → Check if the booster provides the RailCom cutout and if the decoders send RailCom-messages.

tams elektronik

**Hotline**

If problems with your adapter occur, our hotline is pleased to help you (mail address on the last page).

**Repairs**

You can send in a defective adapter for repair (address on the last page). In case of guarantee the repair is free of charge for you. With damages not covered by guarantee, the maximum fee for the repair is 50 % of the current sales price according to our valid price list. We reserve the right to reject the repairing of a module when the repair is impossible for technical or economic reasons.

Please do not send in decoders for repair charged to us. In case of warranty we will reimburse the forwarding expenses up to the flat rate we charge according to our valid price list for the delivery of the product. With repairs not covered by guarantee you have to bear the expenses for sending back and forth.

## 8. Guarantee bond

For this product we issue voluntarily a guarantee of 2 years from the date of purchase by the first customer, but in maximum 3 years after the end of series production. The first customer is the consumer first purchasing the product from us, a dealer or another natural or juristic person reselling or mounting the product on the basis of self-employment. The guarantee exists supplementary to the legal warranty of merchantability due to the consumer by the seller.

The warranty includes the free correction of faults which can be proved to be due to material failure or factory flaw. With kits we guarantee the completeness and quality of the components as well as the function of the parts according to the parameters in not mounted state. We guarantee the adherence to the technical specifications when the kit has been assembled and the ready-built circuit connected according to the manual and when start and mode of operation follow the instructions.

We retain the right to repair, make improvements, to deliver spares or to return the purchase price. Other claims are excluded. Claims for secondary damages or product liability consist only according to legal requirements.

Condition for this guarantee to be valid, is the adherence to the manual. In addition, the guarantee claim is excluded in the following cases:

- if arbitrary changes in the circuit are made,
- if repair attempts have failed with a ready-built module or device,
- if damaged by other persons,
- if damaged by faulty operation or by careless use or abuse.

## 9. EU declaration of conformity

 This product conforms with the EC-directives mentioned below and is therefore CE certified.

2004/108/EG on electromagnetic. Underlying standards: EN 55014-1 and EN 61000-6-3. To guarantee the electromagnetic tolerance in operation you must take the following precautions:

- Connect the transformer only to an approved mains socket installed by an authorised electrician.
- Make no changes to the original parts and accurately follow the instructions, connection diagrams and PCB layout included with this manual.
- Use only original spare parts for repairs.

2011/65/EG on the restriction of the use of certain hazardous substances in electrical and electronic equipment (ROHS). Underlying standard: EN 50581.

## 10. Declarations conforming to the WEEE directive



This product conforms with the EC-directive 2012/19/EG on waste electrical and electronic equipment (WEEE).

Don't dispose of this product in the house refuse, bring it to the next recycling bay.

tams elektronik

tams elektronik

Information and tips:

<http://www.tams-online.de>

Warranty and service:

Tams Elektronik GmbH

Fuhrberger Straße 4

DE-30625 Hannover

fon: +49 (0)511 / 55 60 60

fax: +49 (0)511 / 55 61 61

e-mail: [modellbahn@tams-online.de](mailto:modellbahn@tams-online.de)

