

# FD-4

Funktionsdecoder  
**Motorola-II-Format**

Function decoder  
**Motorola-II-Format**

Décodeur de fonctions  
**Format-Motorola II**

Func tiedecoder  
**Motorola-II-format**

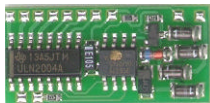

■ **Anleitung**

■ **Manual**

■ **Mode d'emploi**

■ **Handleiding**

Art.-Nr. 22-01-038





## Table of contents

How to use this manual	19
Intended use	19
Safety instructions	19
EMC declaration	21
Information: Motorola I and Motorola II format	22
Operation overview	22
Technical specifications	24
Checking the package contents	24
Required tools and consumables	24
Safe and correct soldering	25
Performing a visual check	25
Mounting the function decoder	26
Setting the decoder address	28
Reset	28
FAQ	28
Manufacturer's note	29
Certification	29
Conditional warranty	30
Connections Diagram (Fig. 1)	I
Circuit Diagram (Fig. 2)	II

(Pages I and II in the centre of this handbook are removeable.)

## How to use this manual

If you have no specialist technical training, this manual gives step-by-step instructions for safe and correct fitting of the module, and operation. Before you start, we advise you to read the whole manual, particularly the chapter on safety instructions and the FAQ chapter. You will then know where to take care and how to prevent mistakes which take a lot of effort to correct.

Keep this manual safely so that you can solve problems in the future. If you pass the kit on to another person, please pass on the manual with it.

## Intended use



### Caution:

Integrated circuits are very sensitive to static electricity. Do not touch components without first discharging yourself. Touching a radiator or other grounded metal part will discharge you.

The module can be used according to the specifications of this manual. It is designed for a mounting in a model railway locomotive or in a model railway carriage. It evaluates the Motorola II format data sent by the digital central unit to its address. The decoder has 7 outputs for the connection of optional accessories.

The module is not suitable for children under the age of 14.

Reading, understanding and following the instructions in this manual are mandatory for the user. Any other use of the module is inappropriate and invalidates any guarantees.

## Safety instructions



### Mechanical hazards

Cut wires can have sharp ends and can cause serious injuries. Watch out for sharp edges when you pick up the PCB.

Visibly damaged parts can cause unpredictable danger. Do not use damaged parts: recycle and replace them with new ones.

### **Electrical hazards**

- Do not touch powered, live components.
- Do not touch conducting components which are live due to malfunction.
- Avoid short circuits.
- Do not connect the circuit to a higher voltage than designed.
- Impermissibly high humidity.
- Condensation building up can cause serious injury due to electrical shock.

Take the following precautions to prevent this danger:

- Never perform wiring on a powered module.
- Only use low power for this module as described in this manual and only use certified transformers.
- Connect transformers and soldering stations only in approved mains sockets installed by an authorised electrician.
- Observe cable diameter requirements.
- Assembling the kit should only be done in closed, clean, dry rooms. Beware of humidity.
- If the humidity in the room is too high, please do not start working until after a minimum of 2 hours of acclimatisation.
- Use only original spare parts if you have to repair the kit or the ready-built module.

### **Fire risk**

Touching flammable material with a hot soldering iron can cause life-threatening fire, burns and toxic smoke. Connect your soldering iron or soldering station only when actually needed. Use the correct soldering iron or station and never leave a hot soldering iron or station unattended.

## **Thermal danger**

A hot soldering iron or liquid solder accidentally touching your skin can cause skin burns. As a precaution:

- use a heat-resistant mat during soldering,
- always put the hot soldering iron in the soldering iron stand,
- point the soldering iron tip carefully when soldering, and
- remove liquid solder with a thick wet rag or wet sponge.

## **Dangerous environments**

A working area that is too small or cramped is unsuitable and can cause accidents, fires and injury. Prevent this by working in a clean, dry room with enough freedom of movement.

## **Other dangers**

Children can cause any of the accidents mentioned above because they are inattentive and not responsible enough. Children under the age of 14 should not be allowed to work with this kit or the ready-built module.

Little children can swallow small components with sharp edges. Life threatening! Do not allow components to reach small children.

In schools, training centres, clubs and workshops, assembly must be supervised by qualified personnel.

In industrial institutions, health and safety regulations applying to electronic work must be adhered to.

## **EMC declaration**

This product is developed in accordance with the European standards EN 55014 and EN 50082-1, tested corresponding to the EC - directive 89/336/EEG (EMVG of 09/11/1992, electromagnetic tolerance) and meets legal requirements.

To guarantee the electromagnetic tolerance you must take the following precautions:

- Connect the transformer only to an approved mains socket installed by an authorised electrician.
- Make no changes to the original parts and accurately follow the instructions, circuit diagram and PCB layout included with this manual.
- Use only original spare parts if you have to repair the kit or the ready-built module.

## **Information: Motorola I and Motorola II format**

The digital driving data is differently encoded and transmitted in the (old) Motorola I format and the (new) Motorola II format. The function decoder FD-4 is designed to evaluate data in Motorola II format. This limits its use in Motorola I format.

Since data of the auxiliary functions F1 to F4 sent in Motorola I Format cannot be evaluated by the locomotive decoder, it is not possible to switch these functions on or off when using Motorola I format.

Unlike the Motorola II format, no absolute direction data is sent in Motorola I format, but a single driving signal reverses the direction of travel.

## **Operation overview**

The decoder is designed for operation in Motorola **II** format and can be adjusted to one of 255 addresses. It evaluates the digital data sent by the central unit to its address and switches the accessories connected to the seven outputs via the functions "function" or the auxiliary functions F1 and F2. The auxiliary functions F3 and F4 are not available with the FD-4.

### **Function lighting**

The lighting can be switched on and off according to the direction of travel from the central unit via the function "function". In addition, another optional accessory (e.g. cab lighting, carriage lighting) can be switched on and off independent of the direction of travel.

## Auxiliary functions F1 and F2

Each of the auxiliary functions F1 and F2 can switch two outputs. Accessories with a maximum current consumption of 500 mA each, can be connected to each of the outputs. Parallel switching of the outputs is also possible. In this way accessories with a maximum current consumption of up to 900 mA can be switched.

## Restrictions in Motorola I format

It is possible to control an accessory via the function "function" independent of the direction of travel. Switching accessories according to the direction of travel or via the functions F1 and F2 is not possible.

## Point connections

X1	Return conductor for all functions.
X2 und X3	Connections to the rails .
X4 und X5	Two accessories with a maximum current consumption of 500 mA* each or one accessory with a maximum current consumption of 900 mA*. Switched via F2.
X6	Lighting for reverse direction. Switched via "function".
X7 und X8	Two accessories with a maximum current consumption of 500 mA* each or one accessory with a maximum current consumption of 900 mA*. Switched via F1.
X9	Lighting for forward direction. Switched via "function".
X10	Accessory with a maximum current consumption of 900 mA*. Switched via "function" independent of the direction of travel.

\* Maximum current consumption of all accessories = 1.500 mA



## Technical specifications

Data format	Motorola II
Supply voltage	12-22 Volt digital voltage
Current consumption (without connected loads)	ca. 10 mA
Max. current per function output	500 mA
Max. total current	1.500 mA
Protected to	IP 00
Ambient temperature in use	0 - + 60° C
Ambient temperature in storage	-10 - + 80° C
Comparative humidity allowed	max. 85 %
Dimensions	ca. 12,5 x 27,5 x 3,5 mm
Weight	ca. 2 g

## Checking the package contents

Check the contents of the package for completeness:

- 1 module
- 1 manual

## Required tools and consumables

Make sure you have the following tools, equipment and materials ready for use:

- a heat-resistant mat
- a soldering iron stand with tip-cleaning sponge
- a small side cutter and wire stripper
- an electronic soldering iron (max. 30 Watt) with a fine tip
- tin solder (0,5 mm. diameter)
- wire (diameter:  $\geq 0,08 \text{ mm}^2$  for all connections)

## Safe and correct soldering



### Caution:

Incorrect soldering can cause fires (through excessive heat). Avoid this danger by reading the chapter **Safety instructions** again and following the directions given.

If you have had training in soldering you can skip this chapter.

- When soldering electronic circuits never use soldering-water or soldering grease. They contain acids that can corrode components and copper tracks.
- Only use tin solder SN 60 Pb (i.e. 60 % tin, 40 % lead) with rosin-based flux.
- Solder fast: long soldering can destroy components and copper tracks, and damages through plated holes.
- Use a small soldering iron with max. 30 Watt. Keep the soldering tip clean so the heat of the soldering iron is applied to the solder point effectively.
- Apply the soldering tip to the soldering spot in such a way that the part and the soldering spot are heated at the same time. Simultaneously add solder (not too much). As soon as the solder becomes liquid take it away. Hold the soldering tip at the spot for a few seconds so that the tin solder finds its way, then remove the soldering iron.
- Do not move the component for about 5 seconds after soldering. A glossy and perfect soldering spot should remain.
- To make a good soldering joint you must use a clean and unoxidised soldering tip. Clean the soldering tip with a damp piece of cloth, a damp sponge or a piece of silicon cloth.

## Performing a visual check

Damaged materials can cause injury. Parts damaged during transit can also be dangerous. Check the module for damage, missing parts or poor soldering. If you find damage, return the module for exchange.

## Mounting the function decoder

Open the locomotive or the carriage housing. Locate the position for the decoder.

Follow the connections diagrams (fig. 1a and 1b)! Solder the connections to the rails at points X2 and X3.

### Connecting the lighting and other accessories

Follow the connections diagrams (fig. 1a and 1b)!

Disconnect any existing diodes in the leads to the lamps. Connect the lamps for forward motion to X9 and the lamps for reverse motion to point X6. If the lamps are already connected with one side to locomotive ground, you must solder in a diode between the decoder and the lamp (see fig. 1a) or you must connect the second side of the lamps according to fig. 1b to the return conductor (point X1).

Connect accessories which are switched via the function "function" and are independent of the direction of travel (e.g. carriage lighting, cab lighting) to point X10.

Connect other accessories (e.g. smoke generator, noise module), which are switched by the functions F1 and F2, to the points X4, X5, X7 and X8. The accessories connected to the points X7 and X8 and to the points X4 and X5 are jointly switched on and off via the functions F1 resp. F2. If you want to connect an accessory with a current consumption of more than 500 mA you must connect the two outputs in parallel (fig. 1a and 1 b, connection to X4 and X5).

#### **Caution:**

The current consumption of all connected accessories may not exceed 1.500 mA!

You can connect the second side of the accessories either to the return conductor (point X1) or to ground. If connecting the accessory to ground you must solder in a diode.

 **Caution:**

The return conductor for all functions (point X1) must under no circumstances be connected to ground. Possible short circuit! The locomotive decoder will be damaged in operation.

**Tip:** If the second side of the lamps is connected to locomotive ground the lamps often flicker in operation. You can avoid the flickering of the lamps if you connect the second side to the return conductor (point X1) instead of locomotive ground.

 **Caution:**

If you connect the loads to the return conductor for all functions (point X1), the load must be insulated. The loads must not make contact with metal parts of the locomotive or the carriage. Possible short circuit! The decoder will be damaged in operation.

### Connecting the LEDs

The function outputs of the locomotive decoder switch against decoder ground. For that reason you must connect the cathode (-) of the LED to the output of the relevant function.

 **Caution:**

If you use light-emitting diodes (LEDs) you must always operate them via a series resistor.

LEDs are available in many different models. There are LEDs with 2-5 mA, but also LEDs with 15-30 mA power consumption. The series resistor limits the current flow of the LED and will need to be calculated for each model. Ask for the max current rating when buying your LEDs.

You can connect several LEDs in parallel to each output. In this case every LED must have a series resistor of its own. If you connect several LEDs to one output in series, only one series resistor is needed. The number of LEDs connected in series to one output depends on the digital voltage.

You can determine the number of the LEDs that can be connected in series to one output from the following formula:

$$\boxed{(\text{number of LEDs} + 2) \times 1,5 < \text{digital voltage}}$$

## Fixing the decoder

After completing all connections fix the decoder with double-sided adhesive tape, for example.

## Setting the decoder address

Before setting the decoder address at least one lamp must be connected. Make sure that the central unit is not transmitting an address (reset).

Some types of central units do not allow to access to the programming modus when the Motorola II format is set. These central units must be set to Motorola I format to program the locomotive decoder.

First enter the new address at the central unit, then the old one. The decoder is delivered with address "40" set. Operate the direction switch and hold it in the position "change direction" until the connected lamp flashes. Now the new address is set.

## Reset

If the decoder does not respond to its address or if you have forgotten the address, switch the decoder off and shunt the connection points X11 and X12 (by soldering a wire). Switch the decoder on again. It now sets the adjustments it had when delivered and the connected lamp flashes to confirm this data. Switch off the decoder again and disconnect the shunt between the connections points X11 and X12. Now you can re-set the decoder.

## FAQ

- Parts are getting too hot and/or start to smoke.



**Disconnect the system from the mains immediately!**

Possible cause: Short circuit. The decoder is connected to locomotive or the carriage ground.

→ Check the connections. A short circuit can result in irreparable damage.

- The lighting does not correspond to the direction of travel.

Possible cause: The forward and backward light connections have been exchanged.

→ Check the connections.

Possible cause: The locomotive decoder in the train is not connected correctly.

→ Check the connections.

- The lamps flicker (this is not a defect).

Possible cause: The lamp is connected with one side to locomotive ground.

→ If you do not want the lamp to flicker, disconnect it from locomotive ground, insulate it and connect it to the return conductor (point X1).

If you cannot find the problem, please return the decoder for repair (address on the cover page).

## Manufacturer's note

According to DIN VDE 0869, the person who builds this kit or brings the circuit into operation is the manufacturer of the product. If he sells the product to another person he is responsible for passing on all the relevant papers. Domestic appliances assembled from a kit are deemed industrial products and must comply with health and safety regulations.

## Certification

This product conforms with the EC- directive 89/336/EEG on electromagnetic radiation and is therefore CE certified.

## Conditional warranty

This product is guaranteed for two years. The warranty includes free repair if the problem is due to material failure or incorrect assembly of the module by us. We guarantee the quality of the components.

Other claims are excluded. By law, we are not responsible for damages or secondary damages in connection with this product. We retain the right to repair, make improvements, supply spare parts or return the purchase price.

The following invalidate the warranty:

- using an unsuitable soldering iron, solder containing liquid acids or similar,
- if damage is caused by not following the instructions in this manual or the circuit diagram,
- if the circuit has been altered and repair attempts have failed,
- if arbitrary changes in the circuit are made,
- if parts are stored incorrectly and if the wires to the switches, the power resistors, etc. are made incorrectly,
- if the copper tracks or soldering points are damaged,
- if parts are placed incorrectly or the circuit is connected incorrectly,
- if damage occurs due to an overload of the circuit,
- if the wrong power or current is connected,
- if damaged by other persons,
- if damaged by the wrong use or abuse of the circuit,
- if parts are damaged due to static because they were touched before a discharge is performed.

# Anschlußplan - Connections diagram - Schema de connexion - Aansluit plan

■ ■ ■ Fig. 1

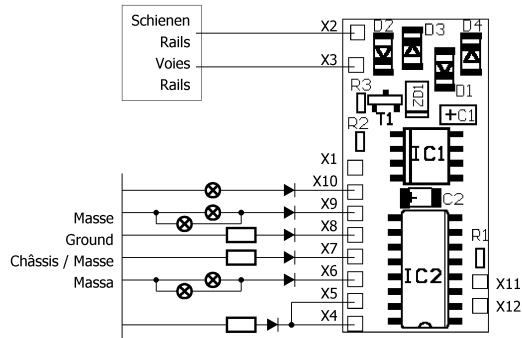

**Fig. 1a:**

Verbindung des 2. Anschlusses mit Masse  
 Connection of the 2nd side to ground  
 Raccordement des fonctions via le châssis / masse  
 Verbinding van de 2e aansluiting met de massa

➤ Diode 1N4007 oder ähnlich /  
 or similar / ou similaire /  
 of gelijkwaardig

▭ Beliebiger Verbraucher  
 (z.B. Rauchgenerator,  
 Führerstandsbeleuchtung,  
 Geräuschmodul)  
 Optional accessories  
 (e.g. smoke generator,  
 cab lighting, noise module)  
 Consommateurs divers  
 (par ex. fumigène, éclairage  
 cabine, module sonore)  
 Willekeurige verbruiker  
 (b.v. rookgenerator,  
 machinistenhuisverlichting,  
 geluidsmodule)

**Fig. 1b:**

Anschluß bei Verwendung des Rückleiters X1  
 Connection when using the return conductor X1  
 Raccordement des fonctions vi la borne commune X1  
 Aansluiten bij gebruik van de retourleiding X1

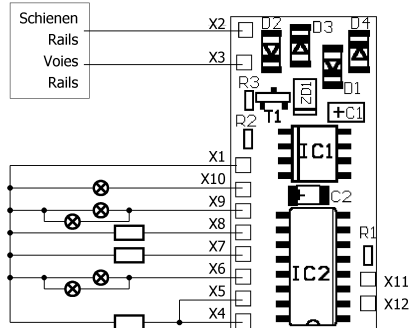

X2/X3	Schienen / Rails Voies / Rails
X1	Rückleiter für alle Funktionen Return conductor for all functions Retour pour toutes les fonctions Retourdraad voor alle functies
X10	"function" an/aus "function"on/off "function"marche / arret "function"aan/uit
X9	Beleuchtung Vorwärtsfahrt Lampe vorne: weiß - Lampe hinten: rot Lighting forward direction Lamp front: white - Lamp back: red Feux marche avant Lampe avant: blanche - Lampe arrière: rouge Verlichting vooruitrijden Lampe voor: wit - Lampe achter: rood
X7/X8	<b>F1</b>
X6	Beleuchtung Rückwärtsfahrt Lampe vorne: rot - Lampe hinten: weiß Lighting reverse direction Lamp front: red - Lamp back: white Feux marche arrière Lampe avant: rouge - Lampe arrière: blanche Verlichting achteruitrijden Lampe voor: rood - Lampe achter: wit
X4/X5	<b>F2</b>
X11/X12	Reset



## Schaltplan - Circuit diagram - Schéma de commutation - Schakelplan

■ ■ ■ Fig. 2

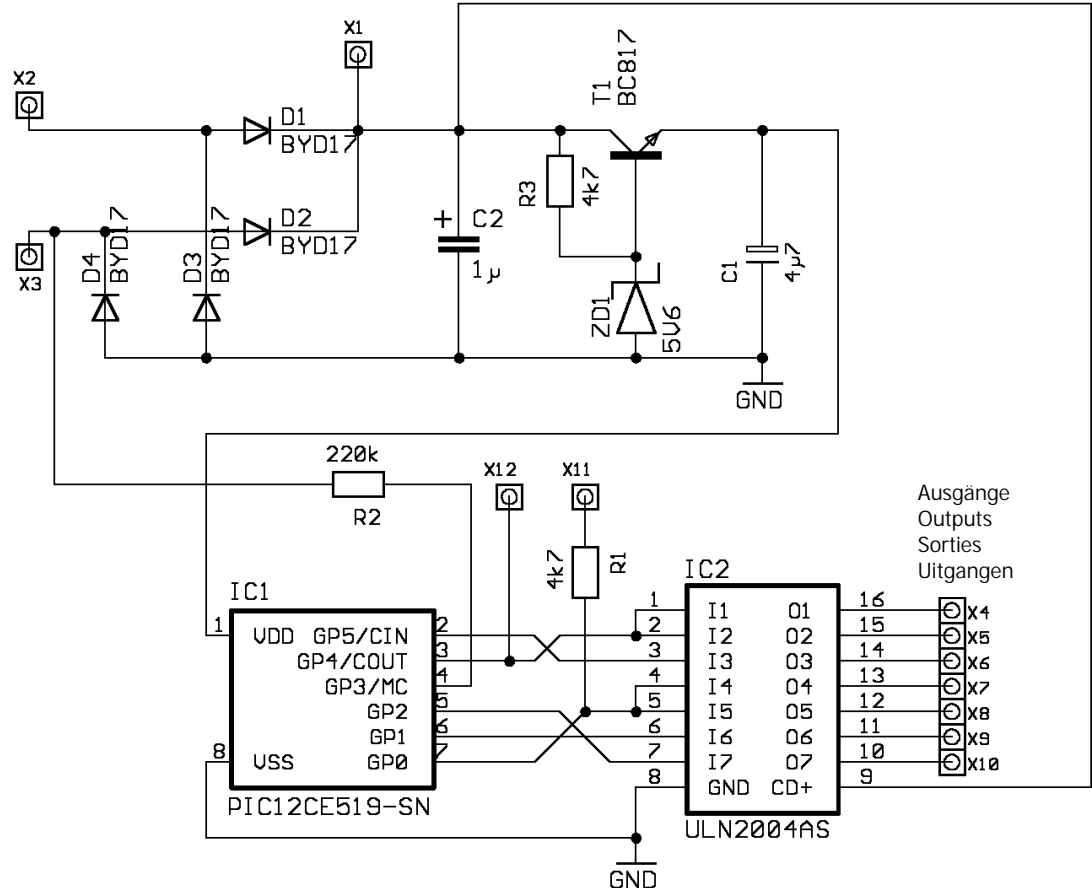

Aktuelle Informationen und Tipps:

Information and tips:

Informations et conseils:

Actuele informatie en tips:

**<http://www.tams-online.de>**

Garantie und Service:

Warranty and service:

Garantie et service:

Garantie en service:

## **Tams Elektronik GmbH**

Rupsteinstraße 10

D-30625 Hannover

fon: 0049 (0)511 / 55 60 60

fax: 0049 (0)511 / 55 61 61

e-mail: [modellbahn@tams-online.de](mailto:modellbahn@tams-online.de)