

Manual

Locomotive decoders LD-G-42 and LD-W-42

DCC

MM



LD-G-42

Item numbers

41-04420

41-04421

41-04422

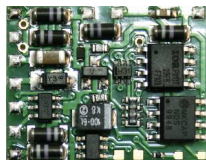

LD-W-42

Item numbers

41-05420

41-05421

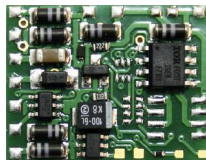

tams elektronik



Contents

1. Getting started.....	4
2. Safety instructions.....	6
3. Safe and correct soldering.....	9
4. Operation overview.....	10
4.1. Digital operation.....	10
4.2. Analogue mode.....	11
4.3. Overload protection.....	13
4.4. Motor control.....	15
4.5. Automated processes.....	17
4.6. Function outputs.....	18
4.7. Triggering the actions.....	20
4.8. Feedback with RailCom®.....	20
5. Technical specifications.....	22
6. Connections.....	23
6.1. Connector pin assignment LD-G-42.....	24
6.2. Connector pin assignment LD-W-42.....	25
6.3. Using decoders with interface connectors.....	26
6.4. Use of the LD-G-42 in locomotives with a.c. motor.....	27
6.5. Mounting decoders without interface.....	27
6.6. Connecting LEDs to the function outputs.....	30
6.7. Connecting inductive loads.....	32
6.8. Connecting the switching input.....	33
6.9. Connecting a buffer capacitor/buffer circuit.....	35
6.10. Fixing the decoder.....	36
7. Programming.....	37

8.	Configuration variables and registers.....	39
8.1.	Basic settings.....	40
8.2.	Setting the motor control.....	41
8.3.	Function mapping.....	44
8.4.	Effects of the outputs.....	51
8.5.	Settings for the switching input.....	53
8.6.	RailCom settings.....	54
8.7.	Settings for driving operation.....	55
8.8.	Settings for analogue mode.....	57
8.9.	Response threshold of the overload protection.....	58
8.10.	Setting the address.....	59
8.11.	Auxiliary functions.....	60
8.12.	Information.....	61
9.	Check list for troubleshooting.....	62
10.	Guarantee bond.....	65
11.	EU Declaration of Conformity.....	66
12.	Declarations concerning the WEEE directive.....	66
13.	The asterisks **.....	67

Version 1.0 | 06/2021 | © Tams Elektronik GmbH

All rights reserved, in particular the right of reproduction, distribution and translation. Copies, reproductions and alterations in any form require the written permission of Tams Elektronik GmbH. We reserve the right to make technical changes.

Printing the manual

The formatting is optimised for double-sided printing. The standard page size is DIN A6. If you prefer a larger display, printing on DIN A5 is recommended.

1. Getting started

How to use this manual

This manual will help you step by step to mount and commission the decoder safely and correctly. Before you connect the decoder and put it into operation, please read this manual completely, particularly the chapter on safety instructions and the checklist for trouble shooting. You will then know where to take care and how to prevent mistakes which take a lot of effort to correct.

Keep this manual safely so that you can solve problems in the future. If you pass the decoder on to another person, please pass on the manual with it.

Intended use

The locomotive decoders LD-G-42 and LD-W-42 are designed to be operated according to the instructions in this manual in model building, especially in digital model railroad layouts. Any other use is inappropriate and invalidates any guarantees.

The locomotive decoders should not be mounted by children under the age of 14.

Reading, understanding and following the instructions in this manual are mandatory for the user.

Available versions

Connecting wires / Interface	LD-G-42 (item number)	LD-W-42 (item number)
without wires	41-04420	41-05420
with wires (cable length: 100 mm)	41-04421	41-05421
according to NEM 652 (8-pole)	41-04422	–

Checking the package contents

Please make sure that your package contains:

one or five locomotive decoders, depending on the version with or without soldered connecting wires resp. with or without interface connector.

N.B. For production reasons the board is not completely assembled. This is not a fault.

For mounting and connecting decoders without interface you need:

- a soldering iron with temperature control and a thin tip and a deposit stand or a controlled soldering station
- a scraper, rag or sponge
- a heat-resistant pad
- a small pair of side cutters and wire strippers
- tweezers and flat-nose pliers if necessary
- electronic solder (preferably 0.5 to 0.8 mm diameter)

In order to connect decoders without interface or soldered connecting wires you will need wire. Recommended cross sections:

- $\geq 0,04 \text{ mm}^2$ for the connections to the function outputs,
- $\geq 0,05 \text{ mm}^2$ for the connections to the motor and current collectors.

If you want to connect a decoder LD-G-42 to an a.c. motor you need:

- a load control adapter LRA (item number 70-02105 or 70-02106) or
- a permanent magnet (e.g. item number 70-04100, 70-04200 or 70-04300) or
- a motor modification set (e.g. item number 70-40110, 70-40210 or 70-40310).

To bridge short current interruptions you need:

- an electrolytic capacitor with a capacity of 100 to 470 μF and a proof voltage of minimum 25 V or
- a buffer circuit, e.g.
 - USV-mini 0.47 (capacity 0.47 F, item no. 70-02215 or 70-02216)
 - USV mini 1.0 (capacity 1.0 F, item no. 70-02225 or 70-02226)
 - USV mini 1.5 (capacity 1.5 F, item no 70-02235 or 70-02236).

To trigger switching operations automatically, you need:

- a reed contact 1 x closing contact (e.g. item-no. 84-53110) or
- a Hall-sensor (e.g. item-no. 84-53210)
- permanent magnets (e.g. neodymium magnets \varnothing 3mm, thickness = 2 mm, item-no. 84-53990)

2. Safety instructions

**Caution:**

Integrated circuits (ICs) are inserted on the decoder. They are sensitive to static electricity. Do not touch components without first discharging yourself. Touching a radiator or other grounded metal part will discharge you.

Mechanical hazards

Cut wires can have sharp ends and can cause serious injuries. Watch out for sharp edges when you pick up the PCB.

Visibly damaged parts can cause unpredictable danger. Do not use damaged parts: recycle and replace them with new ones.

Electrical hazards

- Touching powered, live components,
- touching conducting components which are live due to malfunction,
- short circuits and connecting the circuit to another voltage than specified,
- impermissibly high humidity and condensation build up

can cause serious injury due to electrical shock. Take the following precautions to prevent this danger:

- Never perform wiring on a powered module.
- Assembling and mounting the kit should only be done in closed, clean, dry rooms. Beware of humidity.
- Only use low power for this module as described in this manual and only use certified transformers.
- Connect transformers and soldering irons only in approved mains sockets installed by an authorised electrician.
- Observe cable diameter requirements.
- After condensation build up, allow a minimum of 2 hours for dispersion.
- Use only original spare parts if you have to repair the kit or the ready-built module.

Fire risk

Touching flammable material with a hot soldering iron can cause fire, which can result in injury or death through burns or suffocation. Connect your soldering iron or soldering station only when actually needed. Always keep the soldering iron away from inflammable materials. Use a suitable soldering iron stand. Never leave a hot soldering iron or station unattended.

Thermal danger

A hot soldering iron or liquid solder accidentally touching your skin can cause skin burns. As a precaution:

- use a heat-resistant mat during soldering,
- always put the hot soldering iron in the soldering iron stand,
- point the soldering iron tip carefully when soldering, and
- remove liquid solder with a thick wet rag or wet sponge from the soldering tip.

Dangerous environments

A working area that is too small or cramped is unsuitable and can cause accidents, fires and injury. Prevent this by working in a clean, dry room with enough freedom of movement.

Other dangers

Children can cause any of the accidents mentioned above because they are inattentive and not responsible enough. Children under the age of 14 should not be allowed to mount vehicle decoders.



Caution:

Little children can swallow small components with sharp edges, with fatal results! Do not allow components to reach small children.

In schools, training facilities, hobby and self-help workshops, the assembly, installation and operation of electronic modules must be supervised by trained personnel.

In commercial facilities, the relevant accident prevention regulations must be observed.

3. Safe and correct soldering

**Caution:**

Incorrect soldering can cause dangers through fires and heat. Avoid these dangers by reading and following the directions given in the chapter **Safety instructions**.

- Use a soldering iron with temperature control, which you set to approx. 300 °C.
- Only use electronic solder with a flux.
- Never use soldering fluid or soldering grease when soldering electronic circuits. These contain an acid that destroys components and conductor paths.
- Solder quickly: Soldering for too long can detach solder pads or tracks or even destroy components.
- Hold the soldering tip on the soldering point so that it touches the wire and the pad at the same time. Add (not too much) solder simultaneously. As soon as the solder begins to flow, remove it from the soldering point. Then wait a moment for the solder to flow well before removing the soldering iron from the soldering joint.
- Do not move the created solder joint for about 5 seconds.
- A clean, non-oxidized soldering tip is essential for a perfect soldering joint and good soldering. Therefore, before each soldering, wipe off excess solder and dirt with a damp sponge, a thick damp cloth or a silicone wiper.
- After soldering, check (preferably with a magnifying glass) whether connections or tracks have been bridged with solder by mistake. This can lead to malfunction or destruction of components or, in the worst case, the complete circuit. You can re-liquefy excess solder with the clean hot soldering tip. The solder then flows from the board onto the soldering tip.

4. Operation overview

4.1. Digital operation

The locomotive decoder is a multiple protocol decoder, that can operate with and automatically recognise both DCC or Motorola formats.

	DCC	Motorola (MM)
Number of addresses	127 basic addresses or 10.239 extended addresses	255
Speed level modes	14, 28 or 128	14
Programming	configuration variables (direct programming, DCC conform) or POM (programming on main = main track programming)	registers

4.2. Analogue mode

The locomotive decoder can also be used in analogue model railway layouts run with an A.C. or D.C. speed control. Please note: The use of an A.C. speed control is factory set. The change is only possible by reprogramming the CV / the register with a digital control unit, so not in pure analogue operation.



Caution:

Old analogue driving transformers (e.g. models in a blue housing from Märklin**) are not suitable for use with digital decoders in analogue operation! These transformers have been designed for the older supply voltage of 220 V and, due to construction, generate very high excess voltage impulses when changing the driving direction. When using them with the modern supply voltage of 230 V too high excess voltage impulses can occur, damaging electronic parts on the decoder. For that reason only use driving transformers designed for a net voltage of 230 V.

Automatic analogue recognition

When putting the vehicle on the rails the decoder recognizes automatically if it is run in analogue or digital mode and sets the corresponding operation mode. The automatic analogue recognition can be switched off, e.g.

- if the decoder suddenly switches to analogue mode in digital operation (e.g. as a result of interference voltages whose cause is difficult to localise);
- if a value for the Packet Time Out is programmed to perform a forced stop in case of track voltage failure or shutdown.

Switching the function outputs

Switching the function outputs on or off is not possible in analogue mode. The outputs can be programmed with the digital central unit so that they are either switched on or off in analogue mode. The effects set for the outputs are active in analogue mode as well.

Outputs that are switched depending on the direction are switched on or off in analogue mode according to the direction of travel. When operated in analogue d.c. layouts this applies only to lamps or accessories where the return conductor is connected to the decoder's common return conductor for all function outputs.

Other functions active in analogue mode

The settings made in the CVs / registers for

- the maximum speed
 - the starting and braking decelerations
 - and the load control (for the LD-G-42)
- are also taken over in analogue mode.

4.3. Overload protection

The LD-G-42 and LD-W-42 locomotive decoders have overload protection which protects them from damage if the permissible total current is exceeded or if the motor output is short-circuited (the maximum form of an overload). If an overload is detected, the motor that normally requires the most current is switched off.

When the motor is switched off, activated lights and other accessories remain on and the decoder continues to react to switching commands for the outputs. After about 5 seconds the motor is switched on again. If the overload still exists, it is switched off again immediately. By setting a lower speed level, the load can be reduced, if necessary, to such an extent that the overload protection no longer responds and the locomotive can be moved to an accessible location for closer examination and troubleshooting.

The response threshold of the overload protection can be adjusted by

- change of the time period in which an overload occurs before the motor is switched off ("short-circuit duration") and/or
- change in sensitivity, i.e. the magnitude of the overload at which the overload is detected ("short-circuit sensitivity").

Overload at an output

In case of a short-circuit at one output or if the maximum current at one of the outputs is exceeded, the overload protection of the decoder is ineffective as long as the total current of the decoder is not also exceeded. The output in question will be damaged.

 **Attention:**

By lowering the overload response threshold, the influence of short-term interference voltages from the motor or connected consumers is to be reduced. This prevents the motor from being switched off although the permissible total current has not been exceeded. Before lowering the response threshold, the motor current must always be measured and the proper functioning of the motor and the gear unit checked.

 **Attention:**

When a short circuit occurs that bypasses components on the decoder either to each other or to track voltage, the overload protection is not effective. Examples:

- contact between the decoder and the rails or metal parts of the vehicle;
- contact between not-isolated decoder connecting wires and the rails or metal parts of the vehicle;
- contact between accessories connected to the common return conductor of the decoder and the rails or metal parts of the vehicle.

 **Attention:**

Malfunctions of the locomotive motor (e.g. the so-called "sparking of the brushes") can cause extreme interference current, possibly damaging components on the decoder. The decoder's overload protection is without effect with this extremely high current.

4.4. Motor control

Pulse width modulation

The different decoder types are designed to optimally control their particular fitting motor types.

Decoder type	for	PWM	Suitable for coreless (Faulhaber) motors
LD-G-42	DC motors	28 kHz	yes
LD-W-42	AC motors	60 Hz	no

Load control

The LD-**G**-42 for DC motors has a load control, the LD-**W**-42 for AC motors does not have this function.

The load control influences the motor voltage to keep the locomotive with a set speed level at constant velocity, independent of additional loads (e.g. running up a gradient, coupled carriages).

It is possible to switch on and off the load control by varying a CV-variable of the decoder. The parameters of the load control may be altered, in order to adapt the decoder to the motor's individual characteristics.

Parameters of the load control

The load control is determined by three parameters (KP, KI and KD) which have to be coordinated in order to achieve optimal driving characteristics. Each of the load control parameters is assigned to a configuration variable.

KP: The proportional component of the load control ensures the difference between the set and the present value being as small as possible. It cannot have the value "0" at any time. This component affects the basic speed. In case the set value is too small the

locomotive runs too slowly. In case the set value is too high the locomotive stutters while moving.

KI: The integral component of the load control ensures the remaining difference between the set and the present value is reduced to 0 and so for the correction of very small divergences. If the set value is too high the locomotive stutters massively while moving.

KD: The differential component of the load control ensures that the control is not converted too quickly. If the set value is too low, the locomotive stutters. If it is too high, the locomotive rocks while moving.

Gain factor

The basis for the influence of the load control on the motor voltage is the voltage returned by the motor during the measuring period. Depending on the individual characteristics, these values may be too high or too low. The effects are that the vehicle reaches its maximum speed already at a speed level below the highest speed level or does not reach it at all at the highest speed level. To compensate for these effects, the values sent by the engine can be increased or decreased by adjusting the amplification factor.

Velocity characteristic

By adjusting the starting, middle and maximum speed, the decoder can be adapted to the driving characteristics of the motor and the characteristic driving speeds of the locomotive type. From these 3 points the decoder generates a speed characteristic curve which is linear between the starting and middle speed and between middle and maximum speed.

When the speed level mode is set to 28 speed levels, it is possible to assign any motor voltage to all of the 28 speed levels as an alternative to the linear velocity characteristic. This allows the programming of a velocity characteristic which adjusts the individual driving characteristics of the motor. The set values are saved in the alternative velocity table.

Shunting gear

It is possible to switch into the shunting gear mode via a function key (in state of delivery F3), when so programmed. In the shunting gear mode, the velocity of all speed levels is reduced to approx. 50 % compared to the set velocity.

Acceleration and brake delay

It is possible to program the acceleration and brake delay individually via the central unit. When so programmed, it can be switched on and off with a function key (in state of delivery F4).

4.5. Automated processes

The control software in the locomotive decoder allows you to automate procedures and to reduce complex processes to one keystroke.

Shunting function

Shunting gear and shunting light can be assigned to the same function key. Then, when switching to shunting gear (and the associated reduction in speed), the shunting light (white front and rear lighting) is automatically switched on and the direction-dependent lighting is switched off.

4.6. Function outputs

The decoder has four function outputs (F0f, F0r, AUX1, AUX2) with a maximum current of 300 mA each for the connection of additional accessories (e.g. lighting, smoke generator, electrical coupling). Note: The maximum total current of the decoder (including motor) is 1,500 mA.

Function mapping according to RCN-227

Assigning the functions to the outputs follows RailCommunity standard RCN-227. It is possible to assign one or several outputs to each function (F0 to F28, separately for forward and backward motion for each function). In addition, it is possible to assign another function as an "OFF"-switch to the functions.

This mode of function mapping allows to implement special features, e.g.:

- Switching on and off depending on the direction of travel.
- Shunting light: When switching to shunting operation the signals for shunting locomotive are switched on and those for standard operation switched off.
- Switching off the locomotive 's taillights when connecting wagons.

Effects of the outputs	adjustable for outputs			
	F0f	F0r	AUX1	AUX2
Switching on and off depending on the direction of travel	F0f	F0r	AUX1	AUX2
Shunting light	F0f	F0r	AUX1	AUX2
Inverted switching	F0f	F0r	AUX1	AUX2
Flashing	F0f	F0r	AUX1	AUX2
Kick function	F0f	F0r	AUX1	AUX2
Dimming	F0f	F0r	---	---

Programming the effects	
Switching depending on the direction of travel	Function Mapping
Shunting light	Function Mapping
<p>Inverted switching</p> <p>When set to position "on" the assigned function output will be switched off, when set to position "off" switched on.</p>	CV programming (CV 58-60)
<p>Flashing</p> <p>By assigning the flashing function to 2 outputs and the "inverted switching" function to one of the two outputs, an alternating flashing is generated.</p> <p>The flashing frequency is set separately for each output.</p>	CV programming (CV 58-60, CV 101-104)
<p>Kick function</p> <p>The outputs first receive full voltage for a maximum of approx. 25.5 seconds and are then switched off. The kick time is set separately for all outputs.</p> <p>Example of use: Some types of electrical couplings require full voltage to decouple. However, the voltage should be switched off after uncoupling in order to protect the couplings.</p>	CV programming (CV 58-60, CV 99)
<p>Dimming</p> <p>To reduce the voltage at the output.</p> <p>Example of use: The lights of older vehicles intended for analogue operation can be dimmed and then do not need to be replaced after the decoder has been installed.</p>	CV programming (CV 47-48)

4.7. Triggering the actions

The function outputs are switched on and off and the shunting gear and acceleration/deceleration are (de)activated:

- through the assigned function(s) and / or
- automatically via the switching input. The switching input is triggered via external contacts, e.g. via reed contact or Hall sensors in combination with permanent magnets in the track.

Assignment of the actions to the functions (Function Mapping)

The assignment of the actions controlled by the decoder to the functions is freely selectable, each separately for forward and reverse travel.

Actions	DCC format	MM format
Outputs F0f, F0r, AUX1 and AUX2	F0 to F28	F0 to F4
Shunting gear		
Acceleration / braking delay		

4.8. Feedback with RailCom®

The locomotive decoders LD-G-42 and LD-W-42 are RailCom transmitters and meet the requirements of the RailCommunity standard RCN-217 "RailCom DCC feedback protocol" (status 01.12.2019) for mobile decoders (vehicle decoders). RCN-217 has been published on:

www.railcommunity.org

Sending RailCom messages is possible in layouts with a DCC signal on the rails only. It is not possible to use the RailCom-function in a pure Motorola environment.

Background information: RailCom-messages of vehicle decoders

In channel 1, the vehicle decoders transmit their DCC address after each DCC command directed to any vehicle decoder. Channel 1 can be set "dynamically", i.e. the decoder will only transmit its address in channel 1 until a DCC command is directed to it. This frees the channel for the messages of other decoders to which no command has yet been sent or which are not yet known to the system.

In channel 2, vehicle decoders send their feedback as soon as a DCC command is sent to their address.

Background information: Dynamic RailCom information

"Dynamic information" mean contents of CVs (RailComCVs 64-127) which change during operation (e.g. real speed, reception statistics, tank content). If needed, they are sent by the decoder spontaneously.

The reception statistics are kept by the vehicle decoder, and reported as number of faulty data packages in relation to the total number of data packages. These statistics allow conclusions on the transmission quality between vehicle and rails.

The locomotive decoders LD-G-42 and LD-W-42 can send the following dynamic RailCom information:

- reception statistics

RailCom® is a registered trademark of Lenz Elektronik GmbH. In order to increase the readability of this text, we do without referring to this with every use of the term RailCom.

5. Technical specifications

Data format	DCC and MM
Feedback log	RailCom
Supply voltage	12-24 Volt digital voltage or analogue driving transformer (direct or alternating voltage)
Current consumption (without connected loads) max.	max. 30 mA
Max. total current	1,500 mA
Max. current for motor	1,000 mA
Number of outputs	4
Max. current / output	300 mA
Number of inputs	1
Connection for buffer capacitor or buffer circuit	1
Buffer capacitor	Capacity: 100 to 470 μ F Proof voltage: \geq 35 V
Connection for control line of buffer circuit	according to RCN 530 (switches to ground)
Interface (depending on the decoder type and the version)	LD-G-42: 8 poles according to NEM 652 LD-W-42: ---
Protected to	IP 00
Ambient temperature in use	0 ... +60 °C
Ambient temperature in storage	-10 ... +80 °C
Comparative humidity allowed	max. 85 %
Dimensions PCB	approx. 21,8 x 17,2 x 4 mm
Weight	without wires: approx. 1,6 g with wires: approx. 2,5 g with NEM 652: approx. 2,7 g

6. Connections

Avoid irreparable damage!

Observe the following instructions to avoid damage to the decoder:

1. No conductive connections to metal parts or rails!

Avoid all conductive connections between the decoder or consumers connected to the return conductor for all functions on the one hand, and metal parts of the vehicle or the rails on the other hand. Connections are caused e.g. by insufficiently insulated connecting cables (even at the stripped ends of unused connecting cables!) or insufficient fastening and insulation of the decoder or consumers. Danger of short circuit! In this case the overload protection of the decoder is ineffective!

2. Do not connect the return conductor to vehicle ground!

You should under no circumstances connect the decoder's common return conductor for all function outputs to vehicle ground. Risk of short circuit!

3. Exclude overload!

Before connecting the motor, lights and additional accessories, check that the current is below the maximum permissible values and that the total current is not exceeded. If the permissible current is exceeded, the decoder may be damaged during commissioning.

4. Do not use old analogue driving transformers!

Old analogue driving transformers (e.g. models with blue housing from Märklin**) are not suitable for the use of digital decoders in analogue mode! These transformers are designed for the formerly common mains voltage of 220 V and generate very high overvoltage impulses when switching the driving direction. When used with today's usual mains voltage of 230 V, such high overvoltage pulses can occur that damage to the components on the decoder is caused.

6.1. Connector pin assignment LD-G-42

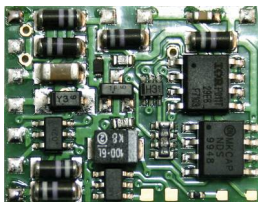
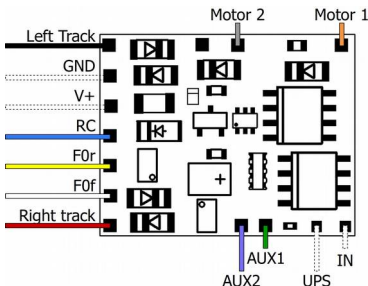

LD-G-42

	Colour of wire	Connection (for use of settings in state of delivery)	
Left track	black	Left current collector (or slider)	
GND		Negative pole (-) of buffer capacitor / Earth connection IN	
V+		Positive pole (+) of buffer capacitor	→ INFO page 26
RC	blue	Common return conductor for all function outputs (+)	
F0r	yellow	Lighting backward motion (function key F0)	
F0f	white	Lighting forward motion (function key F0)	
Right track	red	Right current collector (or vehicle ground)	
Motor 2	grey	Motor connection 2	
Motor 1	orange	Motor connection 1	
AUX2	violet	AUX2 (function key F2)	
AUX1	green	AUX1 (function key F1)	
UPS		Control line for buffer circuit	
IN		Switching input	

6.2. Connector pin assignment LD-W-42

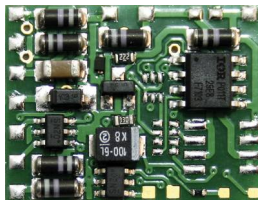
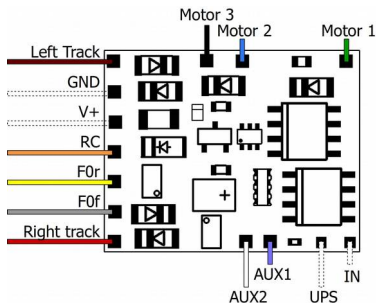

LD-W-42

	Colour of wire	Connection (for use of settings in state of delivery)	
Left track	brown	Left current collector (or slider)	
GND		Negative pole (-) of buffer capacitor / Earth connection IN	
V+		Positive pole (+) of buffer capacitor	→ INFO page 26
RC	orange	Common return conductor for all function outputs (+)	
F0r	yellow	Lighting backward motion (function key F0)	
F0f	grey	Lighting forward motion (function key F0)	
Right track	red	Right current collector (or vehicle ground)	
Motor 3	black	Motor connection 3	
Motor 2	blue	Motor connection 2	
Motor 1	green	Motor connection 1	
AUX2	white	AUX2 (function key F2)	
AUX1	violet	AUX1 (function key F1)	
UPS		Control line for buffer circuit	
IN		Switching input	

Info about the connections V+ and RC

The two connections are equivalent; they can be used either

- as return conductors for the function outputs,
- as a connection for the positive pole of a supporting electrolytic capacitor or a buffer circuit,
- or as a connection for the voltage supply of a Hall sensor.

Please note: Only one variant is shown in the illustrations.

6.3. Using decoders with interface connectors

Many recent locomotives with d.c. motor are equipped ex works with an interface socket. Using a decoder with a suitable connector saves separating the connections and soldering works at the locomotive.

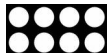

The LD-G-42 locomotive decoder is available with 8-pin interface according to NEM 652. The interface enables you to connect the decoder to the motor, the rail current collectors, the lighting and additional accessories.

**Caution:**

The 8-pole interface plug must be plugged onto the socket in such a way that the markings are superimposed after installation.

Since this interface has no reverse polarity protection, it is possible to insert the plug into the socket rotated by 180 degrees. The decoder is then usually irreparably damaged when put into operation.

Tip: The marker is sometimes difficult to see (or not present). It is (or should be) on the side where the orange connection cable (for motor connection 1) is located.

6.4. Use of the LD-G-42 in locomotives with a.c. motor

The LD-G-42 has been designed to control direct current (d.c.) motors, for that reason it cannot be connected directly to alternating current (a.c.) motors. You can control a.c. motors with the LD-G-42 and benefit of the load control when

- mounting a load control adapter (e.g. item number 70-02105 or 70-02106) between a.c. motor and decoder or
- replacing the field coil of the a.c. motor by a permanent magnet (e.g. item number 70-04100, 70-04200 or 70-04300).

6.5. Mounting decoders without interface

Locate the position for the decoder after opening the locomotive housing. Disconnect the motor from the rail current collectors or the change-over switch from the motor and rails if you have a locomotive with electronic change-over switch. The change-over switch is no longer necessary, you can remove it.



Caution:

The interference suppression devices mounted to the motor or the connecting wire must not be removed! Motor and interference suppression devices are one unit. If even one part is removed, it can cause extreme interference!

Connecting the decoder to the motor

Connect the decoder to the rail current collectors and to the motor according to the connection drawings Fig. 1 or Fig. 2.

Only for analogue operation on 2-wire DC systems: If the direction of travel of the locomotive in analogue operation does not correspond to the direction of travel set on the transformer, you must exchange the connections leading to the rail current collectors / the slider.

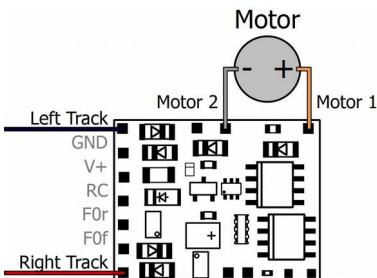

Fig. 1: Connection of an d.c. motor and the power supply

Left track
= left current collector
or slider

Right track
= right current collector
or vehicle ground

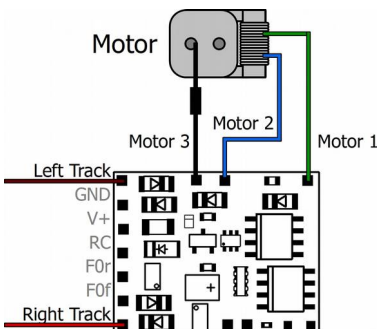

Fig. 2: Connection of an d.c. motor and the power supply

Left track
= left current collector
or slider

Right track
= right current collector
or vehicle ground

Connecting accessories to the outputs

⚠ Caution:

The maximum current of the accessory must not exceed the maximum current of the output to which you connect it. The output may otherwise be irreparably damaged!

Disconnect any existing diodes in the leads to the lamps, otherwise the lamps might not light. Connect the lamps and the accessories to the function outputs of the decoder. If the lamp or the accessory is already connected with one side to vehicle ground, the connection is complete. If not, connect the second side of the lamp or the accessory to the decoder's common return conductor for all function outputs.

You find the factory (default) settings in the lists with the connector pin assignments (pages 24 and 25). You can assign the outputs to the function keys voluntarily by setting the configuration variables.

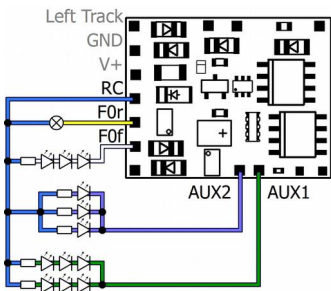

Fig. 3: Examples for the connection of accessories and LEDs to the function outputs

F0r: Light bulb

F0f: serial connection of LEDs

AUX2: parallel connection of LEDs

AUX1: combined parallel and serial connection of LEDs

6.6. Connecting LEDs to the function outputs

The decoder's function outputs switch respective to the decoder ground. For that reason you must connect the cathodes (-) of the LEDs to the function outputs and the anodes (+) to the decoder's common return conductor for all function outputs (RC).



Caution:

You must always operate LEDs via a series resistor! Otherwise LEDs will be destroyed when put into operation or have a significantly reduced duration of life. If you do without a series resistor, other components take over their function (e.g. rails, wheels, current collectors). This can lead to a change in the digital signal and thus to interference in digital operation.

Determine the required resistance value for the peak value of the working voltage available at the return conductor (RC).

Determining the peak value of the working voltage

- with regulated boosters:
output (= track) voltage of the booster - 1 V*
 - with not regulated boosters or analogue driving transformers:
(1,4 x the nominal voltage specified on the transformer) - 1 V*
- * 1 V gets "stuck" in the rectifier of the decoder.

Serial connection of LEDs

When you want to connect several LEDs to one output you can switch them in series via a common series resistor. The current consumption is max. 20 mA for all LEDs, depending on the series resistor's value. The maximum number of LEDs to be connected in series results from

$$\frac{\text{Peak value of the operating voltage}}{\text{- sum of the forward voltages of all LEDs}} > 0$$

The advantage of this solution is the low current consumption.

In order to determine the necessary series resistor for a serial LED's connection first add the forward voltages of all LEDs. The forward voltages depend on the lighting colour and should be given in the technical specifications. In case there is no manufacturer information available, you can take as a basis 4 V for white and blue LEDs and 2 V for yellow, orange, red and green LEDs.

The remaining voltage has to be "eliminated" by a resistor. The formula for the calculation of the resistor is:

$$\text{required } R_V [\text{Ohm}] = (U_B [\text{V}] - \sum U_F [\text{V}]) / (I_F [\text{mA}] \times 0.001)$$

U_B = operating voltage (peak value) | $\sum U_F$ = sum of the forward voltages of all LEDs

I_F = current with max. luminosity

Parallel connection of LEDs

Alternatively, you can connect several LEDs in parallel, each via a series resistor of its own. The current consumption is max. 20 mA for all LEDs, depending on the series resistor's value. The maximum number of LEDs to be connected in parallel results from

maximum current at the output

- sum of the current consumption of all LEDs

> 0

Advantageous with this solution is that the LEDs already lighten when their forward voltage has been reached (2 to 4 V, depending on the fluorescent colour), which makes this solution suitable for analogue mode. Disadvantageous is the high current consumption.

The formula for the calculation of the resistor is:

$$\text{required } R_V [\text{Ohm}] = (U_B [\text{V}] - U_F [\text{V}]) / (I_F [\text{mA}] \times 0.001)$$

U_B = operating voltage (peak value) | U_F = forward voltage of the LED

I_F = current with max. luminosity

In order to save current, you can limit the LEDs' current consumption to 10 mA, which normally does not cause a visible loss of luminance.

6.7. Connecting inductive loads

When connecting inductive loads (e.g. TELEX couplings, relays or other accessories with coils), you should switch a free-wheeling diode (e.g. 1N400x) in parallel, in order to avoid damage at the output. Check to connect the anode of the diode to the function output.

Connecting accessories via a relay

When you want to switch an accessory / accessories via the decoder, which connection would lead to exceeding the maximum current at the output or of the decoder, you can switch the accessories via a relay (e.g. 1xUm 1A 12V, item-number84-61010) and connect them directly to the vehicle's current collector.

The current consumed by the relay depends on its type. The relay named in the example needs approx. 100 mA.

As described in the section "Connecting inductive loads" you should switch a free-wheeling diode (e.g. 1N400x) in parallel to the relay.

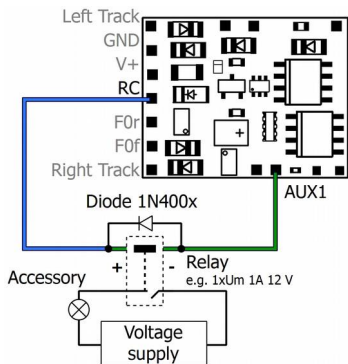

Fig. 4: Connection of an accessory via a relay

6.8. Connecting the switching input

The switching input switches against decoder ground and can therefore be connected to all (external) circuits that can be used to establish a ground connection. It is possible, for example, to connect reed contacts or Hall sensors which establish the ground connection as soon as they enter the magnetic field of a permanent magnet.

Connection of a reed contact

You can use both normally open contacts and changeover switches (changeover contacts).

⚠ Note: The glass bulbs of reed contacts are sensitive to mechanical damage!

Connect reed contacts to the switching input and the ground connection of the decoder (GND). Reed contacts are not polarized, so you can assign the two connections as you wish.

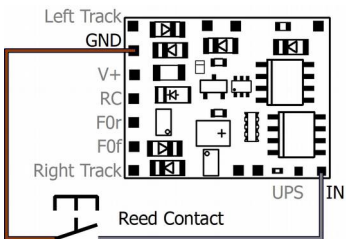



Fig. 6: Connection of a reed contact to the switching input

Connection of a Hall sensor

Pay attention to the correct polarity when connecting Hall sensors.

Assignment of the connections:

Hall sensor	Decoder	 Mixing up the connections "ground terminal" and "supply voltage terminal" may damage the Hall sensor.
Ground terminal (⊥)	Ground terminal (GND)	
Supply voltage terminal (+)	Voltage output (RC or V+)	
Output	Switching input (IN)	

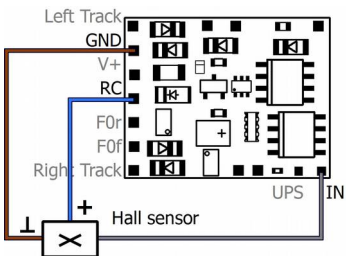

Fig. 7: Connection of a Hall sensor to the switching input

6.9. Connecting a buffer capacitor/buffer circuit

In sections with bad contact to the rails (e.g. when running over turnouts) or with a (e.g. construction-related) bad current consumption of the locomotive, the power supply of the decoder can be interrupted briefly. In analogue mode the effects are usually small, but in digital mode massive disturbances can be the result: e.g. flickering of the lights and stuttering of the motor up to automatic switching to analogue mode. This can be remedied by connecting a backup capacitor or a special buffer circuit.

Connection of a backup capacitor

The capacitor must have a capacity of at least 100 μF and a maximum of 470 F and a proof voltage of at least 35 V. Pay attention to the correct polarity when connecting!

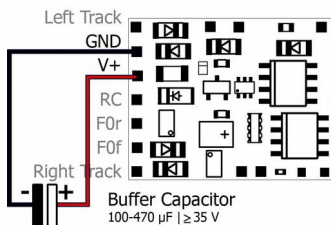

Fig. 8: Connection of a backup capacitor ("buffer electrolytic capacitor")

Connection of a buffer circuit

The capacity of buffer circuits is considerably larger than that of buffer capacitors (e.g. UPS-mini with 0.47 F, 1.0 F or 1.5 F). Use a buffer circuit according to RCN 530 which is connected to ground, e.g. UPS-mini, item numbers 70-0221x, 70-0222x, 70-0223x..

Connect the control line to the "UPS" connector. This ensures that the decoder regulates the charging current and current output and avoids problems e.g. when programming the decoder on the programming track or when switching on the system.

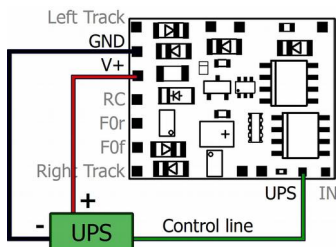

Fig. 9: Connection of a buffer circuit according to RCN 530 (e.g. UPS-mini)

6.10. Fixing the decoder

After having finished all connections you should fix the decoder, to avoid short circuits by contact to metal parts of the vehicle, for example. You can use double sided adhesive tape for it or a decoder holder (item number 70-01810 or 70-01820), for example.

7. Programming

Programming with DCC central units

You can program the configuration variables (CV) of the decoder from the digital central unit, you can use main track programming as well. See the chapter in the manual of your central unit where the byte wise programming of configuration variables (CVs) (Direct programming) and main track programming (POM) are explained.

Register programming is not supported by the decoders. With DCC central units that allow only register-programming it is **not** possible to program the decoders.

Programming with Motorola central units

In Motorola format the settings are saved in registers. The registers have the same numbers as the configuration variables (CVs) for the DCC format.

Please note: If you use a central unit for both DCC and Motorola format it is recommended to program the decoder in the DCC format. After having finished programming the decoder it is possible to control it in Motorola format as well.

Please note: You should connect a lamp or a LED to at least F0f or F0r before starting to program the decoder with a Motorola central unit, as the decoder shows the status of the programming by flashing the lighting connected to these outputs. The flashing frequency shows, which input the decoder expects:

Slow flashing	Fast flashing
Number of the register to be programmed	Value of the register to be programmed

Put the vehicle on a track oval or a track section connected to the central unit's track output (not to the connection for the programming track). Make sure no other vehicle than the one you intend to program is set on the track as the decoder inside this vehicle might be programmed as well.

Starting the programming mode	Programming the decoder
<ol style="list-style-type: none"> 1. Switch on the central unit or perform a reset at the central unit (pushing "stop" and "go") simultaneously. 2. Set the current decoder address (default value: 3) or the address "80". 3. Set all functions to "off". 4. Push button "stop" → switch off the track voltage. 5. Operate the direction switch and hold it in that position. Push the button "go" at once. 6. As soon as the lighting flashes, release the direction switch. 	<ol style="list-style-type: none"> 1. Enter the number of the register as a Motorola-address. If necessary: with a leading "0". 2. Operate the direction switch. → Lighting flashes faster. 3. Enter the value you want to set into the register (as Motorola-address). 4. Operate the direction switch. → Lighting flashes more slowly. <p>If necessary: repeat steps 1 to 4 for all registers to be programmed.</p> <p>Push button "stop".</p>
→ Programming mode	→ End of programming mode

Programming with the Central Station I and the Mobile Station

With the Central Station I or the Mobile Station of Märklin** you can program the registers. Select the article number 29750 from the locomotive database and program the decoder as described for this article in the Central Station's or Mobile Station's manual.

8. Configuration variables and registers

The following lists shows all configuration variables (for the DCC format) and registers (for the Motorola format), that can be set for the locomotive decoders.

Registers and configuration variables (CVs) have identical numbers, they are shown in the tables in the column "No.". The defaults are those values set in the state of delivery and after a reset.

Please note: With variables destined to set several parameters, the input value has to be calculated by adding the numerical values assigned to the desired parameters.

8.1. Basic settings

Name	No.	Input values (Default)	Remarks and tips
Configuration data 1	29	0 ... 255 (14)	Direction "Standard" 0
			Reverse direction 1
			14 speed levels 0
			28 or 128 speed levels 2
			Analogue recognition off 0
			Analogue recognition on 4
			RailCom off 0
			RailCom on 8
			Linear velocity characteristic 0
			Alternative velocity characteristic 16
			Basic addresses 0
			For DCC format only: Extended addresses 32

Example: CV 29 = 0 → Direction = "Standard". 14 speed levels . Automatic analogue recognition = "off". RailCom = "off". Linear velocity characteristic. Basic addresses.

Example: CV 29 = 46 → Direction = "Standard". 28 or 128 speed levels in DCC mode. Automatische Analogerkennung = "on". RailCom = "on". Linear velocity characteristic. Extended addresses.

8.2. Setting the motor control

Optimisation of the driving characteristics

By adjusting the load control (LD-G-42) and the motor characteristics (LD-G-42 and LD-W-42) the decoder is adapted to the individual characteristics of the locomotive motor.

Please note: The installation of a decoder generally increases the effects of vehicle defects on driving characteristics. Locomotive motor, brushes and collector, gearbox, moving parts and current collectors must therefore be in perfect condition. Electrical interference signals (e.g. "brush fire") can massively affect the transmission of digital signals.

Set the CVs in the following order to optimize the driving characteristics:

1. CV 112 "Gain factor" (only LD-G-42)
2. CV 113 to 115 "Load control parameters" (LD-G-42 only)
3. CV 2, CV 5 and CV 6 "Start, maximum and medium voltage"

Setting the load control (LD-G-42 only)

Name	No.	Input values (Default)	Remarks and tips
Load control (LD-G-42 only)	116	0, 1 (1)	Load control off 0
			Load control on 1
Gain factor	112	1...15 (3)	Adaptation of the load control to the individual motor voltage.

Note: The adaptation of CV 112 is only necessary if

- the maximum speed of the locomotive is already reached at a low speed level or
- is not reached at the highest speed level.

Change the value only gradually until the desired maximum speed is reached at the highest speed level.

Setting the parameters of the load control (LD-G-42 only)

Name	No.	Input values (Default)	Remarks and tips
Parameter of load control KP	113	0 ... 255 (32)	= Proportional component of the load control
The parameter KP defines the basic speed. A too small value → locomotive too slow. A too high value → heavy shuttering of the locomotive.			
Parameter of load control KI	114	0 ... 255 (5)	= Integral component of the load control
The parameter KI provides the fine tuning of the load control. The value has to be adjusted in very small steps. A too high value → heavy shuttering of the locomotive.			
Parameter of load control KD	115	0 ... 255 (4)	= Differential component of the load control
The parameter KP defines the basic speed. A too small value → locomotive too slow. A too high value → heavy shuttering of the locomotive.			

Proceed as follows to set the load control parameters:

If the locomotive is shuttering: Increase the value for CV 115 (KD) in steps of 2. If this does not lead to an improvement of the driving characteristics, set the value of CV 115 back to factory setting (default value). Then decrease the value for CV 113 (KP) in steps of 2 and for CV 114 (KI) in steps of 1.

If the locomotive does not have enough power and e.g. gets very slow on the way uphill: Increase the value for CV 114 (KI) in steps of 1, until the locomotive starts to shutter. Then increase the value for CV 115 (KD) in steps of 2. If this does not lead to an improvement or the locomotive starts to shutter immediately after increasing CV 114, set the values for CV 114 and CV 115 back to factory setting (default value) and increase the value for CV 113 (KP) in steps of 5.

If the locomotive is rocking: Decrease the value for CV 115 in steps of 2.

Setting the motor characteristic curve

Name	No.	Input values (Default)	Remarks and tips
Starting voltage (Starting velocity)	2	0 ... 255 (LD-G-42 : 4) (LD-W-42: 64)	= Voltage to be output to the motor at speed level 1. 0 = 0 Volt 255 = max. voltage
Acceleration rate (start-up deceleration)	3	0 ... 255 (LD-G-42 : 10) (LD-W-42: 8)	= Length of the delay before the switching to the next higher / lower speed level when the locomotive is accelerating / braking. The delay is calculated as follows: <u>(value of the CV) x 0,9 sec.</u> number of speed levels
Braking rate (braking deceleration)	4	0 ... 255 (LD-G-42: 8) (LD-W-42: 8)	
Maximum voltage (maximum velocity)	5	0 ... 255 (255)	= Voltage to be output to the motor at the highest speed level. 2 = 0,8 % of the max. voltage 255 = maximum voltage
Medium voltage (center speed)	6	0 ... 255 (LD-G-42: 100) (LD-W-42: 128)	= Voltage at speed level 7 (14-speed mode) or 14 (28-speed mode)
Alternative characteristic curve (only for mode 28 speed steps)	67 68 69 ... 94	0 ... 255 Note: An example of an alternative characteristic curve is set in the default values of CVs 67 – 94.	= Speed table for alternative speed characteristic. A specific motor voltage is assigned to each of the 28 speed steps. 0 = voltage of "0 255 = maximum voltage

8.3. Function mapping

The assignment of the actions controlled by the decoder

- switching the function outputs on and off
- (de)activation of the special functions "Shunting gear" (SG) and "Acceleration/braking delay" (ABD)

to the functions is carried out according to RailCommunity standard RCN-227. Note: Function mapping is not possible with pure Motorola central units.

To get access to the corresponding memory area (the so-called "page"), the values for "Function mapping" must be set in CV 31 and 32 (= default values).

Name	No.	Input values (Default)	Remarks and tips
Index for higher pages	31	0 ... 255 (0)	Function mapping 0
	32	0 ... 255 (42)	Function mapping 42

According to RCN-227, eight configuration variables (CVs) are assigned to each function (F0 to F28) (four each for forward ("f") and reverse ("r")). Six of them are used for the locomotive decoders LD-G-42 and LD-W-42 (3 for forward and 3 for reverse):

- 2 CVs for the outputs (F0f, F0r, AUX1 and AUX2): Here you set which outputs are switched with the function.
- 1 CV for the special functions "Shunting gear" (SG) and "Acceleration/braking delay" (ABD): Here you set which function is used to activate the shunting gear or deactivate the acceleration/braking delay.
- Switch-off function: Here you can define a function with which you can switch **off** the actions assigned to the function when switching **on**. The value "255" determines that the actions are switched off with **no** function.

	Outputs				not in use	Special functions		off/on with function
	F0f	F0r	AUX1	AUX2		SG	ABD	
Values	1	2	4	8	0	4 (on)	8 (off)	F0, F1, F2, ..., F28
Input values	0, 1, 2, 3, 4,..., 31				0	0, 4, 8, 12		0, 1, 2,... 28, 255

CV name	Outputs		not in use		Special functions		off/on with function	
	CV-No.	Default value	CV-No.	Def. value	CV-Nr.	Def.-wert	CV-No.	Default value
F0 f	257	(1) F0f on during forward travel	258	(0)	259	(0)	260	(255)
F0 r	261	(2) F0r on during backward travel	262	(0)	263	(0)	264	(255)
F1 f	265	(4) AUX1 on during forward travel	266	(0)	267	(0)	268	(255)
F1 r	269	(4) AUX1 on during backward travel	270	(0)	271	(0)	272	(255)
F2 f	273	(8) AUX2 on during forward travel	274	(0)	275	(0)	276	(255)
F2 r	277	(8) AUX2 on during backward travel	278	(0)	279	(0)	280	(255)
F3 f	281	(0)	282	(0)	283	(4)	284	(255)
F3 r	285	(0)	286	(0)	287	(4)	288	(255)
F4 f	289	(0)	290	(0)	291	(8)	292	(255)
F4 r	293	(0)	294	(0)	295	(8)	296	(255)
F5 f	297	(0)	298	(0)	299	(0)	300	(255)
F5 r	301	(0)	302	(0)	303	(0)	304	(255)

	Outputs				not in use	Special functions		off/on with function
	F0f	F0r	AUX1	AUX2		SG	ABD	
Values	1	2	4	8	0	4 (on)	8 (off)	F0, F1, F2, ..., F28
Input values	0, 1, 2, 3, 4,..., 31				0	0, 4, 8, 12		0, 1, 2,... 28, 255

CV name	Outputs			not in use		Special functions		off/on with function	
	CV-No.	Default value		CV-No.	Def. value	CV-Nr.	Def.-wert	CV-No.	Default value
F6 f	305	(0)		306	(0)	307	(0)	308	(255)
F6 r	309	(0)		310	(0)	311	(0)	312	(255)
F7 f	313	(0)		314	(0)	315	(0)	316	(255)
F7 r	317	(0)		318	(0)	319	(0)	320	(255)
F8 f	321	(0)		322	(0)	323	(0)	324	(255)
F8 r	325	(0)		326	(0)	327	(0)	328	(255)
F9 f	329	(0)		330	(0)	331	(0)	332	(255)
F9 r	333	(0)		334	(0)	335	(0)	336	(255)
F10 f	337	(0)		338	(0)	339	(0)	340	(255)
F10 r	341	(0)		342	(0)	343	(0)	344	(255)
F11 f	345	(0)		346	(0)	347	(0)	348	(255)
F11 r	349	(0)		350	(0)	351	(0)	352	(255)
F12f	353	(0)		354	(0)	355	(0)	356	(255)
F12 r	357	(0)		358	(0)	359	(0)	360	(255)
F13 f	361	(0)		362	(0)	363	(0)	364	(255)
F13 r	365	(0)		366	(0)	367	(0)	368	(255)

	Outputs				not in use	Special functions		off/on with function
	F0f	F0r	AUX1	AUX2		SG	ABD	
Values	1	2	4	8	0	4 (on)	8 (off)	F0, F1, F2, ..., F28
Input values	0, 1, 2, 3, 4,..., 31				0	0, 4, 8, 12		0, 1, 2,... 28, 255

CV name	Outputs			not in use		Special functions		off/on with function	
	CV-No.	Default value		CV-No.	Def. value	CV-Nr.	Def.-wert	CV-No.	Default value
F14 f	369	(0)		370	(0)	371	(0)	372	(255)
F14 r	373	(0)		374	(0)	375	(0)	376	(255)
F15 f	377	(0)		378	(0)	379	(0)	380	(255)
F15 r	381	(0)		382	(0)	383	(0)	384	(255)
F16 f	385	(0)		386	(0)	387	(0)	388	(255)
F16 r	389	(0)		390	(0)	391	(0)	392	(255)
F17 f	393	(0)		394	(0)	395	(0)	396	(255)
F17 r	397	(0)		398	(0)	399	(0)	400	(255)
F18 f	401	(0)		402	(0)	403	(0)	404	(255)
F18 r	405	(0)		406	(0)	407	(0)	408	(255)
F19 f	409	(0)		410	(0)	411	(0)	412	(255)
F19 r	413	(0)		414	(0)	415	(0)	416	(255)
F20 f	417	(0)		418	(0)	419	(0)	420	(255)
F20 r	421	(0)		422	(0)	423	(0)	424	(255)
F21 f	425	(0)		426	(0)	427	(0)	428	(255)
F21 r	429	(0)		430	(0)	431	(0)	432	(255)

	Outputs				not in use	Special functions		off/on with function
	F0f	F0r	AUX1	AUX2		SG	ABD	
Values	1	2	4	8	0	4 (on)	8 (off)	F0, F1, F2, ..., F28
Input values	0, 1, 2, 3, 4,..., 31				0	0, 4, 8, 12		0, 1, 2,... 28, 255

CV name	Outputs		not in use		Special functions		off/on with function	
	CV-No.	Default value	CV-No.	Def. value	CV-Nr.	Def.-wert	CV-No.	Default value
F22f	433	(0)	434	(0)	435	(0)	436	(255)
F22 r	437	(0)	438	(0)	439	(0)	440	(255)
F23 f	441	(0)	442	(0)	443	(0)	444	(255)
F23 r	445	(0)	446	(0)	447	(0)	448	(255)
F24 f	449	(0)	450	(0)	451	(0)	452	(255)
F24 r	453	(0)	454	(0)	455	(0)	456	(255)
F25 f	457	(0)	458	(0)	459	(0)	460	(255)
F25 r	461	(0)	462	(0)	463	(0)	464	(255)
F26 f	465	(0)	466	(0)	467	(0)	468	(255)
F26 r	469	(0)	470	(0)	471	(0)	472	(255)
F27 f	473	(0)	474	(0)	475	(0)	476	(255)
F27 r	477	(0)	478	(0)	479	(0)	480	(255)
F28 f	481	(0)	482	(0)	483	(0)	484	(255)
F28 r	485	(0)	486	(0)	487	(0)	488	(255)

Example: Programming for shunting operation

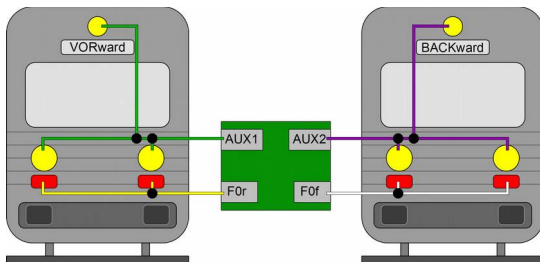

Hint: The connection of the return conductor is not shown.

	Outputs				off/on with function	
	F0f	F0r	1	2		
Values	1	2	4	8	1 ... 254	
CV name	CV-No.	Set value			CV-No.	Set value
F0 f	257	5 (outputs F0f and AUX1)			260	3 (F3=shunting operation)
F0 r	261	10 (outputs F0r and AUX2)			264	3 (F3=shunting operation)
F3 f	265	12 (outputs AUX1 and AUX2)			268	(255 = off)
F3 r	269	12 (outputs AUX1 and AUX2)			272	(255 = off)

With this programming you achieve the following effects when changing to shunting operation (here using function F3):

- the rear end signal for the active direction of motion will be switched off and
- the three-light head end signal will be switched on on both sides.

Example: Programming for rear end signal "off" with coupled carriages

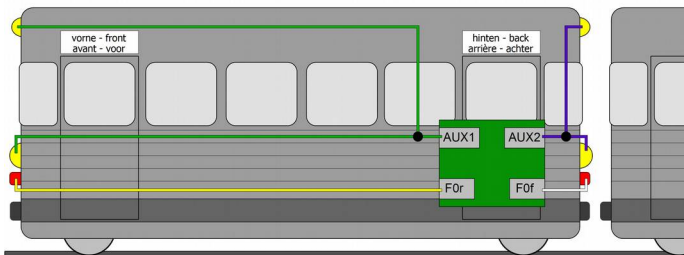

Hint: The connection of the return conductor is not shown.

	Outputs				off/on with function
	F0f	F0r	1	2	
Values	1	2	4	8	1 ... 254
CV name	CV-No.	Set value	CV-No.	Set value	
F0 f	257	5 (outputs F0f and AUX1)	260	5 (F5=coupled carriage)	
F0 r	261	10 (outputs F0r and AUX2)	264	5 (F5=coupled carriage)	
F5 f	297	4 (output AUX1)	268	(255 = off)	
F5 r	301	2 (output F0r)	272	(255 = off)	

With this programming you achieve the following effects when changing to operation with coupled carriages (here using function F5):

- the signals appropriate for the direction of motion will be switched on and
- the signals on the side of the coupled carriages will be switched off.

8.4. Effects of the outputs

Assignment of the effects to the outputs

Name	No.	Input values (Default)	Remarks and tips
F0f	57	0 ... 255 (0)	no effects 0
F0r	58	0 ... 255 (0)	Function inverted 1
AUX1	59	0 ... 255 (0)	Flashing on 2
AUX2	60	0 ... 255 (0)	Kicking on 4

Example: Alternating flashing with AUX1 and AUX2:

→ Input value for AUX1: CV 59 = 2 | Input value for AUX2: CV 60 = 3 (1 + 2)

Flashing frequency

Name	No.	Input values (Default)	Remarks and tips
F0f	101	1 ... 255 (20)	Setting separately for each output. 1 = highest flashing frequency 255 = lowest flashing frequency Note: The flashing function must be switched on for the output. (CV 57 - 60)
F0r	102	1 ... 255 (20)	
AUX1	103	1 ... 255 (20)	
AUX2	104	1 ... 255 (20)	

Kicking time

Name	No.	Input values (Default)	Remarks and tips
Kicking time ("moment-function")	99	0 ... 255 (32)	<p>Setting common for all outputs. 0 = shortest kick time 255 = longest kick time (= 25.5 seconds) Increasing the input value by "1" extends the time period by 0.1 sec.</p> <p>Note: The kick function must be switched on for the output. (CV 57 - 60)</p>

Dimming of the outputs

Name	No.	Input values (Default)	Remarks and tips
F0f	47	1...64 (64)	= Reduction of the voltage applied to the output 1 = lowest voltage 255 = maximum voltage
F0r	48	1...64 (64)	
Note: The outputs AUX1 and AUX2 cannot be dimmed.			

8.5. Settings for the switching input

Name	No.	Input values (Default)	Remarks and tips
Assignment of the functions to the switching input	62	1 ... 255 (0)	F1 1
			F2 2
			F3 4
			F4 8
			F5 16
			F6 32
			F7 64
			F8 128
Minimum switch-on time of the switching input	97	0 ... 255 (0)	<p>= Time period for which the input remains at least on after it has been connected to ground.</p> <p>Increasing the input value by "1" extends the time period by 0.1 sec.</p> <p>0 = 0 sec. (off)</p> <p>255 = 25.5 sec.</p>
<p>Example:</p> <p>The shunting gear (here switched with F3) is to be activated automatically for the duration of the crossing over a switch road (here 10 seconds).</p> <p>CV 62 = 4 (assignment of the switching input to F3)</p> <p>CV 97 = 100 (= 10 seconds).</p>			

8.6. RailCom settings

Name	No.	Input values (Default)	Remarks and tips
Dynamic RailCom information	10	0,1 (0)	off 0
			Reception statistics: The decoder keeps statistics on all DCC packets and reports the number of faulty packets / total number of packets in %. 1
In order to read out RailCom information, you have to make the following additional settings: - CV 29 ("configuration data 1": RailCom on - CV 28 "RailCom channels": at least channel 2 on			
RailCom channels	28	0 ... 7 (3)	no feedback with RailCom 0
			Channel 1 on 1
			Channel 2 on 2
			Dynamic channel 1 use 4 The setting only has an effect if channel 1 is switched on.
Please note that some RailCom detectors can only receive messages on channel 1. For the decoder to send RailCom messages, RailCom must be switched on in CV 29. Further information on RailCom → Section 4.8			

8.7. Settings for driving operation

Consist operation

As a standard, in multiple units (consist operation) you can only control velocity and direction. In CV 21 and 22 you can define additional functions to be switched when using the address for multiple units defined in CV 19. If the value "0" is set, the function will continue to be addressed only via the address set for the vehicle concerned in CV 1 or CV 17 and 18.

Name	No.	Input values (Default)	Remarks and tips
Functions active in consist operation (F1 to F8)	21	0 ... 255 (0)	F1 on 1
			F2 on 2
			F3 on 4
			F4 on 8
			F5 on 16
			F6 on 32
			F7 on 64
			F8 on 128
Functions active in consist operation (F0, F9 to F12)	22	0 ... 31 (0)	F0f on 1
			F0r on 2
			F9 on 4
			F10 on 8
			F11 on 16
			F12 on 32

Braking behaviour with DC voltage

Name	No.	Input values (Default)	Remarks and tips
Braking behaviour with DC voltage	27	0 ... 3 (3)	No braking with d.c. voltage 0
			Braking with negative d.c. voltage 1
			Braking with positive d.c. voltage 2

Tip: It is standard to switch over into analogue mode when applying a d.c. voltage at the rails. In case that the decoder is run in a layout with a braking route based on applying a d.c. voltage (e.g. Märklin** -braking route), the analogue recognition has to be deactivated (in CV 29) to ensure that the locomotive reacts as expected on the braking route.

The setting of the negative or positive d.c. voltage is related to the right rail, as seen in the locomotive's direction of motion.

Setting the Packet Time Out

Name	No.	Input values (Default)	Remarks and tips
Packet Time Out	11	2 ... 255 (16)	Time period between the failure of the digital signal and the change to the alternative operation (analogue operation). Increasing the input value by "1" extends the time period by 10 ms.

Hint: If the decoder is supplied by a buffer circuit, the locomotive would continue running unplanned after an emergency stop or a signal stop caused by switching off the track voltage. To prevent this, you have to set a low value for the Packet Time Out (approx. 16) and switch off the automatic switch-over to analogue operation in CV 29.

8.8. Settings for analogue mode

Name	No.	Input values (Default)	Remarks and tips
Analogue mode	65	0, 1 (1)	= Procedure triggering a change of direction
			Change of polarity (d.c. layouts) 0
			Overvoltage impulse (a.c. layouts) 1
Functions active in analogue mode (F1 to F8)	13	0 ... 255 (0)	F1 on 1
			F2 on 2
			F3 on 4
			F4 on 8
			F5 on 16
			F6 on 32
			F7 on 64
			F8 on 128
Functions active in analogue mode (F0, F9 to F12)	14	0 ... 31 (0)	F0 on 1
			F9 on 2
			F10 on 4
			F11 on 8
			F12 on 16

8.9. Response threshold of the overload protection

Name	No.	Input values (Default)	Remarks and tips
Duration of the overload ("short-circuit duration")	63	0 ... 32 (2)	Time period in which an overload occurs before the motor is switched off. Increasing the input value by "1" extends the time by 0.5 ms. 0 = immediately 32 = 16 ms
magnitude of the overload ("short-circuit sensitivity")	64	0 ... 255 (50)	Magnitude of the overload at which the overload is detected. 50 = 1,500 mA The higher the value, the higher the current at which the overload protection trips. The value of 50 should only be changed in exceptions!

Info: The overload protection switches off the motor (not the function outputs) after the time set in CV 63 if the permissible total current is exceeded or if there is a short circuit at the motor output (the maximum form of an overload).

Short-term interference voltages of the motor or connected loads can cause the motor to switch off, although the permissible total current has not been exceeded and there is no short-circuit at the motor output. In this case the time until the overload protection is activated can be slightly adjusted in CV 63.

Always check the motor current and the correct functioning of the motor and transmission before lowering the response threshold.

8.10. Setting the address

Name	No.	Input values (Default)	Remarks and tips
Basic address	1	1 ... 255 (3)	Range of values: in DCC format: 1 ... 127 in MM format: 1 ... 255
<p>Tip: If a value higher than 127 is set for the basic address and the use of extended addresses in CV 29 is set to off, the decoder does not react to signals in DCC format!</p>			
Extended address	17	192 ... 255 (195)	Only for DCC format. Most central units permit entering extended addresses directly. The CVs 17, 18 and 29 are set automatically to the proper values.
	18	0 ... 255 (232)	
Consist address	19	1 ... 127 (0)	Address for consist operation (multi-traction) In DCC format only!

8.11. Auxiliary functions

Name	No.	Input values (Default)	Remarks and tips
Reset	8	0 ... 255	Any input value restores the settings in state of delivery.
Decoder lock	15	0 ... 255 (3)	Changing the CV values of the decoder is only possible if the values in CV 15 and 16 are identical. By assigning specific values in CV 16 the CVs of decoders with the same address can be changed separately.
	16	0 ... 255 (3)	
Application e.g. for vehicles or train formations with several decoders with the same address (e.g. locomotive, sound, function decoders).			
Index for higher CV-Pages	31	0 (0)	Adjustable in DCC format only! Function mapping 0
	32	0 (42)	Adjustable in DCC format only! Function mapping 42
Note: If different values are entered in CV 31 and/or 32 the function mapping for the function outputs and special functions cannot be changed.			

8.12. Information

Name	No.	Input values (Default)	Remarks and tips
Version	7	---	Read only in DCC format!
Manufacturer	8	--- (62)	Read only in DCC format!
Permitted modes of operation	12	--- (53)	<p>Readable in DCC format only!</p> <p>Defines the permitted modes of operation for the decoder</p> <p>LD-G-42 and LD-W-42: $54 = 1 + 4 + 16 + 32$ $1 = DC \mid 4 = DCC \mid 16 = AC \mid 32 = MM$</p>
Method for function assignment	96	--- (2)	<p>Readable in DCC format only!</p> <p>Defines the method for assigning the functions:</p> <p>2 = Function assignment via CVs 257 to 512 in the bank selected by CV 31 = 0 and CV 32 = 42 with CVs per function according to RailCommunity standard RCN227 section 2</p>

9. Check list for troubleshooting

- Parts are getting very hot and/or start to smoke.



Disconnect the system from the mains immediately!

Possible cause: one or more connections are soldered incorrectly.
→ Check the connections.

Possible cause: Short circuit between the decoder or accessories connected to the retrain conductor for all functions and metal parts of the locomotive or the rails. → Check the connections. A short circuit can result in irreparable damage.

Problems with the driving characteristics

- After programming the decoder the locomotive does not run or runs badly.

Possible cause: The set values for the CV are inconsistent.
→ Perform a decoder reset and program the decoder anew.

- In digital mode the locomotive suddenly runs very fast.

Possible cause: Interfering signals from the layout have switched the decoder to analogue mode. → As the origin of the interfering signals often cannot be found, it is advisable to switch off the automatic recognition of the analogue mode during digital operation.

- The motor is switched off during operation and switched on again after 5 seconds. Immediately afterwards or after a short time, the engine is switched off again and switched on again after 5 seconds. This procedure is repeated continuously. Lights and other loads can be switched on and off.

Possible cause: The overload protection has been activated because the current consumption is higher than the maximum total current of the decoder or there is a short circuit at the motor output. → Check the condition of the motor and the current consumption of the motor

and the additional consumers. Tip: To move the locomotive to an accessible location, it may be sufficient to reduce the speed level considerably.

Possibly the decoder is not suitable for installation in this loco.

- The CV values cannot be read out by RailCom.

Possible cause: RailCom is switched off. → Alter the value of CV 29 (add "8" to the input value).

Problems with switching of the functions

- An accessory / a light does not react to switching commands. Possible cause: The accessory is defective or incorrectly connected. → Check the accessory / the connections.

Possible cause: The output is defective (e.g. due to overload or short circuit). → Send in the decoder for check / repair (with costs).

- The lighting goes on and off when the speed levels are turned up or the lighting cannot be switched on or off.

Possible cause: The speed mode of the decoder and the digital control unit do not correspond. Example: The central is set to the mode 28 speed levels, but the decoder to the mode 14 speed levels. → Change the speed mode at the central and / or at the decoder.

Problems with switching via the switching input

- After passing a permanent magnet in the rails no action is activated. Possible cause: The reed contact or the Hall sensor has been mounted incorrectly. → Check the connections.

Possible cause: The distance to the magnet is too large or the magnet is too weak. → Alter the position of the magnet (if possible) or use a stronger one.

Possible cause: The magnet has been mounted incorrectly polarized. → Alter the mounting direction.

Possible cause: The assignment of the function to the switching input is wrong or the minimum switch-on time is too short. → Check the inputs in CV 62 and 97.

Problems in analogue mode

- The locomotive does not run in analogue mode, the decoder does not work.

Possible cause: The analogue mode is switched off. → Alter the value for CV 29.

- The decoder does not switch to analogue mode (or switches over although it is still digitally controlled).

Possible cause: The value in CV 11 is set too high or too low. → Alter the value and check the settings in operation.

Hotline

If problems with your decoder occur, our hotline is pleased to help you (mail address on the last page).

Repairs

You can send in a defective decoder for repair (address on the last page). In case of guarantee the repair is free of charge for you. With damages not covered by guarantee, the maximum fee for the repair is 50 % of the sales price according to our valid price list. We reserve the right to reject the repairing of a decoder when the repair is impossible for technical or economic reasons.

Please do not send in decoders for repair charged to us. In case of warranty we will reimburse the forwarding expenses up to the flat rate we charge according to our valid price list for the delivery of the product. With repairs not covered by guarantee you have to bear the expenses for sending back and forth.

10. Guarantee bond

For this product we issue voluntarily a guarantee of 2 years from the date of purchase by the first customer, but in maximum 3 years after the end of series production. The first customer is the consumer first purchasing the product from us, a dealer or another natural or juristic person reselling or mounting the product on the basis of self-employment. The guarantee exists supplementary to the legal warranty of merchantability due to the consumer by the seller.

The warranty includes the free correction of faults which can be proved to be due to material failure or factory flaw. With kits we guarantee the completeness and quality of the components as well as the function of the parts according to the parameters in not mounted state. We guarantee the adherence to the technical specifications when the kit has been assembled and the ready-built circuit connected according to the manual and when start and mode of operation follow the instructions.

We retain the right to repair, make improvements, to deliver spares or to return the purchase price. Other claims are excluded. Claims for secondary damages or product liability consist only according to legal requirements.

Condition for this guarantee to be valid, is the adherence to the manual. In addition, the guarantee claim is excluded in the following cases:

- if arbitrary changes in the circuit are made,
- if repair attempts have failed with a ready-built module or device,
- if damaged by other persons,
- if damaged by faulty operation or by careless use or abuse.

11. EU Declaration of Conformity

 This product fulfils the requirements of the following EU directives and therefore bears the CE marking.

2001/95/EU Product Safety Directive

2015/863/EU on the restriction of the use of certain hazardous substances in electrical and electronic equipment (RoHS)

2014/30/EU on electromagnetic compatibility (EMC Directive).
Underlying standards:

DIN-EN 55014-1 and 55014-2: Electromagnetic compatibility - Requirements for household appliances, electric tools and similar electrical appliances. Part 1: Emitted interference, Part 2: Immunity to interference

To maintain electromagnetic compatibility during operation, observe the following measures:

Only connect the supply transformer to a professionally installed and fused earthed socket.

Do not make any changes to the original components and follow the instructions, connection and assembly diagrams in this manual exactly.

Only use original spare parts for repair work.

12. Declarations concerning the WEEE directive



This product complies with the requirements of the EU Directive 2012/19/EC on Waste Electrical and Electronic Equipment (WEEE).

Do not dispose of this product in (unsorted) municipal waste, but recycle it.

13. The asterisks **

This manual mentions the following companies:

Gebr. MÄRKLIN & Cie. GmbH | Stuttgarter Str. 55-57 | D-73033 Göppingen

Information and tips:

<http://www.tams-online.de>

Warranty and service:

Tams Elektronik GmbH

Fuhrberger Straße 4

DE-30625 Hannover

fon: +49 (0)511 / 55 60 60

fax: +49 (0)511 / 55 61 61

e-mail: modellbahn@tams-online.de

