

Manual

Locomotive decoders LD-G-32.2 and LD-W-32.2

DCC

MM



LD-G-32.2

Item no. 41-01420

Item no. 41-01421

Item no. 41-01422

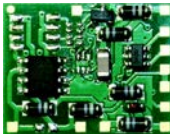

LD-W-32.2

Item no. 41-02420

Item no. 41-02421

tams elektronik



Contents

1. Getting started.....	4
2. Safety instructions.....	6
3. Safe and correct soldering.....	9
4. Operation overview.....	10
4.1. Modes of operation.....	10
4.2. Driving of the motor.....	12
4.3. Function outputs.....	14
4.4. Releasing the functions.....	15
4.5. Automated processes.....	15
4.6. Feedback with RailCom**.....	16
5. Technical specifications.....	17
6. Connections.....	18
6.1. Connector pin assignment LD-G-32.2.....	19
6.2. Connector pin assignment LD-W-32.2.....	20
6.3. Using decoders with interface connectors.....	21
6.4. Use in locomotives with a.c. motor.....	21
6.5. Mounting decoders without interface.....	22
6.6. Connecting LEDs to the function outputs.....	24
6.7. Connecting inductive loads.....	26
6.8. Connecting accessories via a relay.....	26
6.9. Connecting a buffer capacitor.....	27
6.10. Fixing the decoder.....	27
7. Programming.....	28
8. Configuration variables and registers.....	30
9. Check list for troubleshooting.....	41

10. Guarantee bond.....	43
11. EU declaration of conformity.....	44
12. Declarations conforming to the WEEE directive.....	44

© 07/2018 Tams Elektronik GmbH

All rights reserved. No part of this publication may be reproduced or transmitted in any form or by any means, electronic or mechanical, including photocopying, without prior permission in writing from Tams Elektronik GmbH.

Subject to technical modification.

The asterisks **

RailCom® is the registered trademark of:

Lenz Elektronik GmbH | Vogelsang 14 | DE-35398 Gießen

To increase the text's readability we have refrained from referring to this point in each instance.

This manual mentions the following companies:

Gebr. MÄRKLIN & Cie. GmbH | Stuttgarter Str. 55-57 | DE-73033 Göppingen

Uhlenbrock Elektronik GmbH | Mercatorstraße 6 | DE-46244 Bottrop

1. Getting started

How to use this manual

This manual gives step-by-step instructions for safe and correct fitting and connecting of the decoder, and operation. Before you start, we advise you to read the whole manual, particularly the chapter on safety instructions and the checklist for trouble shooting. You will then know where to take care and how to prevent mistakes which take a lot of effort to correct.

Keep this manual safely so that you can solve problems in the future. If you pass the decoder on to another person, please pass on the manual with it.

Intended use

The locomotive decoders LD-G-32.2 and LD-W-32.2 are designed to be operated according to the instructions in this manual in model building, especially in digital model railroad layouts. Any other use is inappropriate and invalidates any guarantees.

The locomotive decoders should not be mounted by children under the age of 14.

Reading, understanding and following the instructions in this manual are mandatory for the user.

Checking the package contents

Please make sure that your package contains:

- one or five locomotive decoders, depending on the version with or without soldered connecting wires resp. with or without interface connector;
- a CD (containing the manual and further information).

N.B. For technical reasons it is possible that the PCB is not completely inserted. This is not a fault.

Available versions

Connecting wires / Interface	LD-G-32.2	LD-W-32.2
without wires	+	+
with wires	+	+
according to NEM 650	8- pole (NEM 652)	–
according to NEM 658	–	–
according to NEM 660	–	–

Required materials

For mounting and connecting decoders without interface you need:

- an electronic soldering iron (max. 30 Watt) or a regulated soldering iron with a fine tip and a soldering iron stand,
- a tip-cleaning sponge,
- a heat-resistant mat,
- a small side cutter, a wire stripper and a pair of tweezers,
- electronic tin solder (0.5 mm diameter).

In order to connect decoders without interface or soldered connecting wires you will need wire. Recommended cross sections:

- $\geq 0,04 \text{ mm}^2$ for the connections to the function outputs;
- $\geq 0,05 \text{ mm}^2$ for the connections to the motor and current collectors.

If you want to connect a decoder LD-**G**-32.2 to an a.c. motor you need:

- a load control adapter LRA (item no. 70-02105 or 70-02106) or
- a permanent magnet (e.g. item no. 70-04100, 70-04200 or 70-04300) or
- a motor modification set (e.g. item no. 70-40110, 70-40210 or 70-40310).

In order to bridge short current interruptions you need:

- an electrolytic capacitor with a capacity of 100 to 470 μF and a proof voltage of minimum 35 V.

2. Safety instructions



Caution:

Integrated circuits (ICs) are inserted on the decoder. They are sensitive to static electricity. Do not touch components without first discharging yourself. Touching a radiator or other grounded metal part will discharge you.

Mechanical hazards

Cut wires can have sharp ends and can cause serious injuries. Watch out for sharp edges when you pick up the PCB.

Visibly damaged parts can cause unpredictable danger. Do not use damaged parts: recycle and replace them with new ones.

Electrical hazards

- Touching powered, live components,
- touching conducting components which are live due to malfunction,
- short circuits and connecting the circuit to another voltage than specified,

▪ impermissibly high humidity and condensation build up

can cause serious injury due to electrical shock. Take the following precautions to prevent this danger:

- Never perform wiring on a powered module.
- Assembling and mounting the kit should only be done in closed, clean, dry rooms. Beware of humidity.
- Only use low power for this module as described in this manual and only use certified transformers.
- Connect transformers and soldering irons only in approved mains sockets installed by an authorised electrician.
- Observe cable diameter requirements.
- After condensation build up, allow a minimum of 2 hours for dispersion.
- Use only original spare parts if you have to repair the kit or the ready-built module.

Fire risk

Touching flammable material with a hot soldering iron can cause fire, which can result in injury or death through burns or suffocation. Connect your soldering iron or soldering station only when actually needed. Always keep the soldering iron away from inflammable materials. Use a suitable soldering iron stand. Never leave a hot soldering iron or station unattended.

Thermal danger

A hot soldering iron or liquid solder accidentally touching your skin can cause skin burns. As a precaution:

- use a heat-resistant mat during soldering,
- always put the hot soldering iron in the soldering iron stand,
- point the soldering iron tip carefully when soldering, and
- remove liquid solder with a thick wet rag or wet sponge from the soldering tip.

Dangerous environments

A working area that is too small or cramped is unsuitable and can cause accidents, fires and injury. Prevent this by working in a clean, dry room with enough freedom of movement.

Other dangers

Children can cause any of the accidents mentioned above because they are inattentive and not responsible enough. Children under the age of 14 should not be allowed to work with this kit or the ready-built module.



Caution:

Little children can swallow small components with sharp edges, with fatal results! Do not allow components to reach small children.

In schools, training centres, clubs and workshops, assembly must be supervised by qualified personnel.

In industrial institutions, health and safety regulations applying to electronic work must be adhered to.

3. Safe and correct soldering

**Caution:**

Incorrect soldering can cause dangers through fires and heat. Avoid these dangers by reading and following the directions given in the chapter **Safety instructions**.

- Use a small soldering iron with max. 30 Watt. Keep the soldering tip clean so the heat of the soldering iron is applied to the solder point effectively.
- Only use electronic tin solder with flux.
- When soldering electronic circuits never use soldering-water or soldering grease. They contain acids that can corrode components and copper tracks.
- Solder quickly: holding the iron on the joints longer than necessary can destroy components and can damage copper tracks or soldering eyes.
- Apply the soldering tip to the soldering spot in such a way that the wire and the soldering eye are heated at the same time. Simultaneously add solder (not too much). As soon as the solder becomes liquid take it away. Hold the soldering tip at the spot for a few seconds so that the solder flows into the joint, then remove the soldering iron.
- The joint should be held still for about 5 seconds after soldering.
- To make a good soldering joint you should use a clean and unoxidised soldering tip. Clean the soldering tip with a damp piece of cloth, a damp sponge or a piece of silicon cloth.
- After soldering check (preferably with a magnifying glass) tracks for accidental solder bridges and short circuits. This would cause faulty operation or, in the worst case, permanent damage. You can remove excess solder by putting a clean soldering tip on the spot. The solder will become liquid again and flow from the soldering spot to the soldering tip.

4. Operation overview

4.1. Modes of operation

Digital operation

The locomotive decoder is a multiple protocol decoder, that can operate with and automatically recognise both DCC or Motorola formats.

The number of addresses is dependant on the format being used:

- Motorola-Format: 255 addresses,
- DCC-Format: 127 Basis-addresses or 10.239 extended addresses.

In the DCC format the decoder can be driven in all speed levels (14, 28 or 128). In the Motorola format the decoder can be driven in 14 or 27 speed levels. Driving all 27 speed levels can be done only with central units which support this mode (e.g. MasterControl). With central units which allow 14 speed levels only, it is only possible to select every second speed level.

Programming the decoders is done:

- in Motorola format by setting the registers,
- in DCC format by setting the configuration variables (direct programming, DCC conform) or by POM (programming on main = main track programming).

Analogue mode

The locomotive decoder can also be used in analogue model railway layouts run with a D.C. speed control, and with restrictions with an A.C. speed control. When putting the vehicle on the rails the decoder recognizes automatically if it is run in analogue or digital mode and sets the corresponding operation mode. The automatic recognition of the analogue mode can be switched off.



Caution:

Old analogue driving transformers (e.g. models in a blue housing from Märklin**) are not suitable for use with digital decoders in analogue operation! These transformers have been designed for the older supply voltage of 220 V and, due to construction, generate very high excess voltage impulses when changing the driving direction. When using them with the modern supply voltage of 230 V too high excess voltage impulses can occur, damaging electronic parts on the decoder. For that reason only use driving transformers designed for a net voltage of 230 V.

Switching the function outputs on or off is not possible in analogue mode. They can be programmed so that they are either switched on or off in analogue mode. The effects set for the outputs are active in analogue mode as well.

Outputs to be switched with F0 are switched on or off in analogue mode according to the direction of travel. When operated in analogue d.c. layouts this applies only to lamps or accessories where the return conductor is connected to the decoder's common return conductor for all function outputs.

The decoders' load control is not active in analogue mode.

4.2. Driving of the motor

Pulse width modulation

The different decoder types are designed to optimally control their particular fitting motor types.

Decoder type	PWM	Suitable for coreless (Faulhaber) motors
LD-G-32.2	32 kHz (fixed)	yes
LD-W-32.2	480 or 60 Hz (to be set)	no

Load control

The LD-**G**-32.2 for DC motors has a load control, the LD-**W**-32.2 for AC motors do not have this function.

The load control influences the motor voltage to keep the locomotive with a set speed level at constant velocity, independent of additional loads (e.g. running up a gradient, coupled carriages).

It is possible to switch on and off the load control by varying a CV-variable of the decoder. The parameters of the load control may be altered, in order to adapt the decoder to the motor's individual characteristics.

Parameters of the load control: The load control is determined by three parameters which have to be coordinated in order to achieve optimal driving characteristics. Each of the load control parameters is assigned to a configuration variable. The parameters are:

KP: The proportional component of the load control ensures the difference between the set and the present value being as small as possible. It cannot have the value "0" at any time. This component affects the basic speed. In case the set value is too small the locomotive runs too slowly. In case the set value is too high the locomotive stutters while moving.

KI: The integral component of the load control ensures the remaining difference between the set and the present value is reduced to 0 and so for the correction of very small divergences. If the set value is too high the locomotive stutters massively while moving.

KD: The differential component of the load control ensures that the control is not converted too quickly. Is the set value too low then the locomotive stutters. If the set value is too high, the locomotive rocks while moving.

Velocity characteristic

The decoder can be adjusted to the driving characteristics of the motor and the characteristic speed of the locomotive type, by setting the starting and maximum velocity. From these two settings the decoder generates a linear velocity characteristic.

When the speed level mode is set to 28 speed levels, it is possible to assign any motor voltage to all of the 28 speed levels as an alternative to the linear velocity characteristic. This allows the programming of a velocity characteristic which adjusts the individual driving characteristics of the motor. The set values are saved in the alternative velocity table.

Shunting gear

It is possible to switch into the shunting gear mode via a function key (in state of delivery F3), when so programmed. In the shunting gear mode, the velocity of all speed levels is reduced to approx. 50 % compared to the set velocity.

Acceleration and brake delay

It is possible to program the acceleration and brake delay individually via the central unit. When so programmed, it can be switched on and off with a function key (in state of delivery F4).

Emergency stop

It is possible to carry out an emergency stop at a change of direction automatically, when so programmed.

4.3. Function outputs

The decoder has function outputs, which are available to connect optional accessories (e.g. lighting, smoke generator, sound module, electric coupling). The accessories' number and type to be connected depends on the outputs' number and maximum current as well as on the maximum total current of the special decoder (see section 5 "Technical specifications").

Effects of the function outputs

It is possible to set the following effects for the function outputs individually:

- Switching on and off depending on the direction of travel.
- Flashing and double flashing. Both the frequency and the keying ratio can be set. E.g. single and double flash lights or strobe lights.
- Dimming: Example of use: The electric bulbs of older vehicles made for analogue operation can be dimmed and thus must not be exchanged after the mounting of the decoder.
- Shunting light: You can program the outputs so that they are switched on generally during shunting operation (to be switched with F3 or F4). The dependence on the direction of travel will be nullified for these outputs during shunting operation.

4.4. Releasing the functions

The function outputs can be released by pushing the function keys. The mapping of the outputs to the function keys and the switching inputs is arbitrary. It is possible to assign several function keys and switching inputs to one output.

Outputs	DCC format	MM format
AUX1 to AUX3	F0 to F12	F0 to F4 or F5 to F9 (= F0 to F4 of a second decoder address)

4.5. Automated processes

The control software in the locomotive decoder allows you to automate procedures and to reduce complex processes to one keystroke.

Dimming depending on the velocity

You can automatically switch functions depending on the velocity when reaching a speed level defined in a CV. You assign an individual voltage to the function outputs for the ranges of speed levels underneath and above the defined speed level. This allows for example to switch on and off the high beam light, to control the cab light or to influence the intensity of the steam output.

Shunting function

You can assign the shunting gear and the shunting light to the same function key. That way you switch on the shunting light automatically when switching into the shunting gear (and thus reducing the velocity).

4.6. Feedback with RailCom**

RailCom is a log for bi-directional communication in digital model railway layouts controlled in DCC-format. It allows e.g. the feedback of the address and the CV values from the decoder to the digital central unit or to special receivers (so-called detectors). The decoders must be designed to send the RailCom messages.

When so programmed, the locomotive decoders LD-G-32.2 and LD-W-32.2 send (continuously) the (basic, extended or consist) address to the detectors (so-called RailCom broadcast datagramm) and transfer a CV message after a DCC CV read-out command.

Sending RailCom messages is only possible in layouts with a DCC signal on the rails. It is not possible to use the RailCom-function in a pure Motorola environment.

5. Technical specifications

Data format	DCC and MM		
Feedback log	RailCom		
Supply voltage	12-24 V digital voltage or max. 18 V analogue voltage		
Current consumption (without connected loads) max.	40 mA		
Max. total current	1.500 mA		
Max. current for motor	1.000 mA		
Number of outputs	3		
Max. current / output	AUX1: 300 mA AUX2: 300 mA AUX3: 200 mA		
Connection for buffer capacitor Capacity Proof voltage	1 100 to 470 μ F \geq 35 V		
Interface (depending on the decoder type and the version)	according to NEM 652		
Protected to	IP 00		
Ambient temperature in use	0 ... +60 °C		
Ambient temperature in storage	-10 ... +80 °C		
Comparative humidity allowed	max. 85 %		
Dimensions PCB	approx. 22x17x6 mm		
Weight	LD-G-32.2	LD-W-32.2	
	without wires	approx. 1.4 g	approx. 1.3 g
	with wires	approx. 2.3 g	approx. 1.9 g
	NEM 652	approx. 2.5 g	---

6. Connections



Note the following comment in order to protect the decoder from (maybe irreparable) damage!

Avoid all conducting connections between the decoder and accessories connected to the decoder's common return conductor for all function outputs on the one hand and metal parts of the vehicle or the rails on the other hand. Connections result for example from badly isolated connecting wires (as well as the stripped ends of connecting wires not in use) or insufficient fixing and isolating the decoder or the accessory, for example. Risk of short circuit! In this case the overload protection of the decoder is not able to protect the decoder from damage.

Before connecting the motor, lighting or other accessories check if their current is below the maximum permissible values and the total current is below the safe load. Should the permissible current be exceeded, this can result in damage to the decoder.

You should under no circumstances connect the decoder's common return conductor for all function outputs to vehicle ground. Risk of short circuit!

Old analogue driving transformers (e.g. models in a blue housing from Märklin**) are not suitable for use with digital decoders in analogue operation! These transformers have been designed for the older supply voltage of 220 V and, due to construction, generate very high excess voltage impulses when changing the driving direction. When using them with the modern supply voltage of 230 V too high excess voltage impulses can occur, damaging electronic parts on the decoder. For that reason only use driving transformers designed for a net voltage of 230 V.

6.1. Connector pin assignment LD-G-32.2

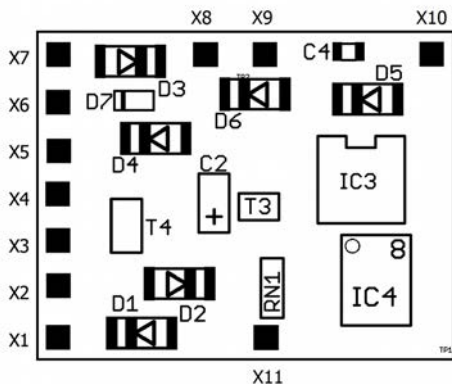
Versions: 8-pole plug (NEM652), with or without wires

LD-G-32.2

	Colour of wire	Connection to (for use of settings in state of delivery)
X1	red	Right current collector (or slider)
X2	white	AUX1 = lighting forward motion (function key F0)
X3	yellow	AUX2 = lighting backward motion (function key F0)
X4	blue	RL = common return conductor for all function outputs (+)
X5		Positive pole (+) of buffer capacitor
X6		Negative pole (-) of buffer capacitor
X7	black	Left current collector (or vehicle ground)
X8	---	not occupied
X9	grey	Motor connection 2 (minus)
X10	orange	Motor connection 1 (plus)
X11	green	AUX3 (function key F1) max. current: 200 mA

6.2. Connector pin assignment LD-W-32.2

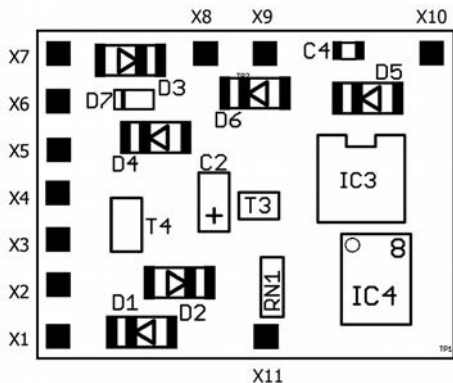

Versions: without / with wires

LD-W-32.2

	Colour of wire	Connection to (for use of settings in state of delivery)
X1	red	Right current collector (or slider)
X2	grey	AUX1 = lighting forward motion (function key F0)
X3	yellow	AUX1 = lighting backward motion (function key F0)
X4	orange	RL = common return conductor for all function outputs (+)
X5		Positive pole (+) of buffer capacitor
X6		Negative pole (-) of buffer capacitor
X7	brown	Left current collector (or vehicle ground)
X8	black	Motor connection 3
X9	blue	Motor connection 2
X10	green	Motor connection 1
X11	violet	AUX3 (function key F1) max. current: 200 mA

6.3. Using decoders with interface connectors

Many recent locomotives with d.c. motor are equipped ex works with an interface socket. Using a decoder with a suitable connector saves separating the connections and soldering works at the locomotive. Possible versions:

	Description	Number of poles	MOROP standard
	6 pole	6	NEM 651
	8 pole	8	NEM 652

The interface enables you to connect the decoder to the motor, the rail current collectors, the lighting and – provided the special connector is designed for it – additional accessories.

When mounting decoders with 6-pole interface connectors according to NEM 651 or 8-pole interface connectors according to NEM 652, take care to put the markings on the connector and on the socket on top of each other.

6.4. Use in locomotives with a.c. motor

The LD-**G**-32.2 has been designed to control direct current (d.c.) motors, for that reason it cannot be connected directly to alternating current (a.c.) motors. You can control a.c. motors with the LD-**G**-32.2 and benefit of the load control when

- mounting a load control adapter between a.c. motor and decoder or
- replacing the field coil of the a.c. motor by a permanent magnet.

6.5. Mounting decoders without interface

Locate the position for the decoder after opening the locomotive housing. Disconnect the motor from the rail current collectors or the change-over switch from the motor and rails if you have a locomotive with electronic change-over switch. The change-over switch is no longer necessary, you can remove it.



Caution:

The interference suppression devices mounted to the motor or the connecting wire must not be removed! Motor and interference suppression devices are one unit. If even one part is removed, it can cause extreme interference!

Connecting the decoder to the motor

Connect the decoder to the rail current collectors and to the motor. Should the locomotive's direction of motion in analogue mode not match the direction of motion set at the speed control you have to swap the connections to the rail current collectors / the slider.

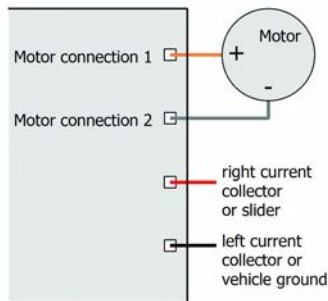

Fig. 1: Connection of an d.c. motor and the power supply

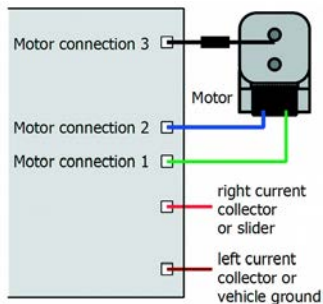

Fig. 2: Connection of an a.c. motor and the power supply

Connecting accessories to the outputs

Disconnect any existing diodes in the leads to the lamps, otherwise the lamps might not light. Connect the lamps and the accessories to the function outputs of the decoder. If the lamp or the accessory is already connected with one side to vehicle ground, the connection is complete. If not, connect the second side of the lamp or the accessory to the decoder's common return conductor for all function outputs.

You find the factory (default) settings in the lists with the connector pin assignments. You can assign the outputs to the function keys voluntarily by setting the configuration variables.

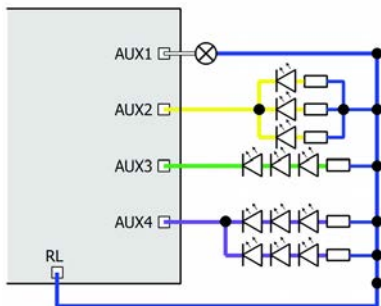

Fig. 3: Examples for the connection of accessories and LEDs to the function outputs

AUX2: parallel connection of LEDs

AUX3: serial connection of LEDs

AUX4: combined parallel and serial connection of LEDs

6.6. Connecting LEDs to the function outputs

The decoder's function outputs switch respective to the decoder ground. For that reason you must connect the cathodes (-) of the LEDs to the function outputs and the anodes (+) to the decoder's common return conductor for all function outputs.



Caution:

If you use light-emitting diodes (LEDs) you must always operate them via a series resistor, otherwise they will be damaged when put into operation or their duration of life will be reduced considerably!

When doing without a series resistor, other components undertake the series resistor's function (e.g. rails, wheels, current connectors), possibly leading to a modification of the data signal and thus to disturbances in digital operation.

Always determine the necessary series resistor's value for the peak value of the available operating voltage. With regulated boosters this corresponds to the specified boosters' output (= track) voltage. With not regulated boosters or analogue driving transformers the peak value is approx. 1,4 fold the nominal voltage specified on the transformer.

Serial connection of LEDs

When you want to connect several LEDs to one output you can switch them in series via a common series resistor. The current consumption is max. 20 mA for all LEDs, depending on the series resistor's value. The maximum number of LEDs to be connected in series results from

$$\frac{\text{Peak value of the operating voltage}}{\text{- sum of the forward voltages of all LEDs}} > 0$$

The advantage of this solution is the low current consumption.

In order to determine the necessary series resistor for a serial LED's

connection first add the forward voltages of all LEDs. The forward voltages depend on the lighting colour and should be given in the technical specifications. In case there is no manufacturer information available, you can take as a basis 4 V for white and blue LEDs and 2 V for yellow, orange, red and green LEDs.

The remaining voltage has to be "eliminated" by a resistor. The formula for the calculation of the resistor is:

$$\text{required } R_V [\text{Ohm}] = (U_B [\text{V}] - \sum U_F [\text{V}]) / (I_F [\text{mA}] \times 0.001)$$

U_B = operating voltage (peak value) | $\sum U_F$ = sum of the forward voltages of all LEDs

I_F = current with max. luminosity

Parallel connection of LEDs

Alternatively, you can connect several LEDs in parallel, each via a series resistor of its own. The current consumption is max. 20 mA for all LEDs, depending on the series resistor's value. The maximum number of LEDs to be connected in parallel results from

maximum current at the output

- sum of the current consumption of all LEDs

> 0

Advantageous with this solution is that the LEDs already lighten when their forward voltage has been reached (2 to 4 V, depending on the fluorescent colour), which makes this solution suitable for analogue mode. Disadvantageous is the high current consumption.

The formula for the calculation of the resistor is:

$$\text{required } R_V [\text{Ohm}] = (U_B [\text{V}] - U_F [\text{V}]) / (I_F [\text{mA}] \times 0.001)$$

U_B = operating voltage (peak value) | U_F = forward voltage of the LED

I_F = current with max. luminosity

In order to save current, you can limit the LEDs' current consumption to 10 mA, which normally does not cause a visible loss of luminance.

6.7. Connecting inductive loads

When connecting inductive loads (e.g. TELEX couplings, relays or other accessories with coils), you should switch a free-wheeling diode (e.g. 1N400x) in parallel, in order to avoid damage at the output. Check to connect the anode of the diode to the function output.

6.8. Connecting accessories via a relay

When you want to switch an accessory / accessories via the decoder, which connection would lead to exceeding the maximum current at the output or of the decoder, you can switch the accessories via a relay (e.g. 1xUm 1A 12V, item-no. 84-61010) and connect them directly to the vehicle's current collector.

The current consumed by the relay depends on its type. The relay named in the example needs approx. 100 mA.

As described in the section "Connecting inductive loads" you should switch a free-wheeling diode (e.g. 1N400x) in parallel to the relay.

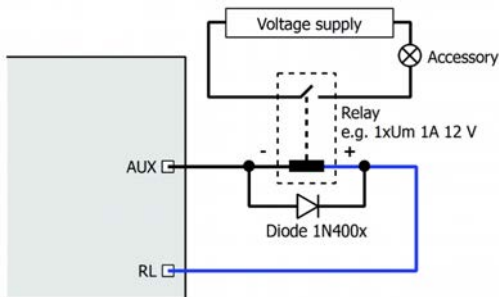

Fig. 4: Connection of an accessory via a relay

6.9. Connecting a buffer capacitor

In sections with bad contact to the rails the power supply of the decoder can be interrupted. Possible consequences are e.g. flickering lighting. In these and similar cases you can find a remedy by connecting a buffer capacitor.

The electrolytic capacitor should have a capacity of minimum 100 μF and a proof voltage of minimum 35 V. Observe the correct polarity when connecting the capacitor!

6.10. Fixing the decoder

After having finished all connections you should fix the decoder, to avoid short circuits by contact to metal parts of the vehicle, for example. You can use double sided adhesive tape for it or a decoder holder (item no. 70-01810 or 70-01820), for example.

7. Programming

Programming with DCC central units

You can program the configuration variables (CV) of the decoder from the digital central unit, you can use main track programming as well. See the chapter in the manual of your central unit where the byte wise programming of configuration variables (CVs) (Direct programming) and main track programming (POM) are explained. With central units that allow only register-programming it is only possible to program the variables CV 1, CV 2, CV 3, CV 4 and CV 29 (= register 1 to 5).

Programming with Motorola central units

In Motorola format the settings are saved in registers.

Please note: If you use a central unit for both DCC and Motorola format it is recommended to program the decoder in the DCC format. After having finished programming the decoder it is possible to control it in Motorola format as well.

Please note: You should connect a lamp or a LED to at least AUX1 or AUX2 before starting to program the decoder with a Motorola central unit, as the decoder shows the status of the programming by flashing the lighting connected to these outputs. The flashing frequency shows, which input the decoder expects:

Slow flashing	Fast flashing
Number of the register to be programmed	Value of the register to be programmed

Put the vehicle on a track oval or a track section connected to the central unit's track output (not to the connection for the programming track). Make sure no other vehicle than the one you intend to program is set on the track as the decoder inside this vehicle might be programmed as well.

Starting the programming mode	Programming the decoder
<ol style="list-style-type: none"> 1. Switch on the central unit or perform a reset at the central unit (pushing "stop" and "go") simultaneously. 2. Set the current decoder address (default value: 3) or the address "80". 3. Set all functions to "off". 4. Push button "stop" → switch off the track voltage. 5. Operate the direction switch and hold it in that position. Push the button "go" at once. 6. As soon as the lighting flashes, release the direction switch. 	<ol style="list-style-type: none"> 1. Enter the number of the register as a Motorola-address. If necessary: with a leading "0". 2. Operate the direction switch. → Lighting flashes faster. 3. Enter the value you want to set into the register (as Motorola-address). 4. Operate the direction switch. → Lighting flashes more slowly. <p style="text-align: center;">Repeat steps 1 – 4 for all registers.</p> <p style="text-align: center;">Push button "stop".</p>
→ Programming mode	→ End of programming mode.

Programming with Motorola central units with restricted input options

Some central units do not allow but input values up to 80 or 99. With the auxillary register 62 values above 80 can be entered.

Programming with the Central Station and the Mobile Station

With the Central Station I or the Mobile Station of Märklin** you can program the registers. Select the article no. 29750 from the locomotive database and program the decoder as described for this article in the Central Station´s or Mobile Station´s manual.

Programming with the CV-Navi

Instead of programming the configuration variables or registers of the decoder using the digital central unit, you can use the free software CV-Navi. You will find the free download under:

www.tams-online.de

A central unit RedBox or Master Control is required for using the software.

8. Configuration variables and registers

The following lists shows all configuration variables (for the DCC format) and registers (for the Motorola format), that can be set for the locomotive decoders.

In the lists you will find in the column "CV-no." the numbers of the configuration variables for programming in DCC format and in the column "Rg.-no." the numbers of the registers for programming in Motorola format. The defaults are those values set in the state of delivery and after a reset.

Please note: With variables destined to set several parameters, the input value has to be calculated by adding the numerical values assigned to the desired parameters.

Setting the address

Name of CVs / registers	CV-no.	Rg-no.	Input value (Default)	Remarks and Tips
Basic address	1	01	1 ... 255 (3)	Range of values in DCC-Format: 1 ... 127
Tip: If a value higher than 127 is set for the basic address and the use of extended addresses in CV 29 is set to off, the decoder does not react to signals in DCC format!				
Extended address	17	04	192 ... 255 (192)	Only for DCC format. Most central units permit entering extended addresses directly. The CVs 17, 18 and 29 are set automatically to the proper values.
	18	05	0 ... 255 (255)	
Consist address	19	53	1 ... 127 (0)	= 2nd address In DCC format only!
2nd Motorola address	114	40	1... 255 (4)	= Address needed to switch additional functions in Motorola format. The function keys F5 to F8 are reached via the function keys F1 to F4, the function key F9 via the function key F0.

Information / Read only

Name of CVs / registers	CV-no.	Rg-no.	Input value (Default)	Remarks and Tips
Version	7	--	---	Read only in DCC format!
Manufacturer	8	--	--- (62)	Read only in DCC format!

Auxiliary functions

Name of CVs / registers	CV-no.	Rg-no.	Input value (Default)	Remarks and Tips
Reset	8	03	0 ... 255	Any input value restores the settings in state of delivery.
Auxiliary register for programming with MM central units	—	62	1...64 (0)	To enable the input of values > 80 with central units allowing the input of values between 0 and 80 only.
<p>The value set in register 62 multiplied by 4 is added to the value of the register to be programmed. Example for inputting the value 137 into register 09:</p> <ol style="list-style-type: none"> 1. $137 / 4 = 34$, remainder 1 2. Programming for register 62 the value 34. 3. Programming for register 09 the value 1. 				

Settings for analogue mode

Name of CVs / registers	CV-no.	Rg-no.	Input value (Default)	Remarks and Tips
Analogue mode	12	06	0, 1 (0)	= Procedure triggering a change of direction
				Overvoltage impulse (a.c. layouts) 0
				Change of polarity (d.c. layouts) 1
iFunctions active in analogue mode (only for F1 to F8, not for F9 to F12)	13	41	0 ... 255 (0)	F1 on 1
				F2 on 2
				F3 on 4
				F4 on 8
				F5 on 16
				F6 on 32
				F7 on 64
				F8 on 128

Basic settings

Name of CVs / registers	CV-no.	Rg-no.	Input value (Default)	Remarks and Tips
Configuration data 1	29	07	0 ... 64 (14)	Direction "Standard" 0
				Reverse direction 1
				14 speed levels 0
				28 or 128 speed levels 2
				Analoge recognition off 0
				Analoge recognition on 4
				RailCom off 0
				RailCom on 8
				Linear velocity charact. 0
				Alternat. velocity charact. 16
Basic addresses 0				
Not for MM mode:				
Extended addresses 32				
<p>Example: CV 29 = 0. → Direction = "Standard". 14 speed levels. Basic addresses. Automatic analogue recognition = "off". RailCom = "off".</p> <p>Example: CV 29 = 46. → Direction = "Standard". 28 or 128 speed levels in DCC-mode. Automatic analogue recognition = "on". RailCom = "on". Extended addresses.</p> <p>Tip: If the use of extended addresses is activated in CV 29, the decoder does not react to signals in Motorola format!</p>				
Configuration data 2	49	22	0 ... 255 (73)	Load control inactive 0
				LD-G-32.2 only:
				Load control active 1
				Shunting gear at F1 2
				Shunting gear at F2 4
				Shunting gear at F3 8
				Shunting gear at F4 16
				Acceleration and brake delay to be switched at F3 32
				Acceleration and brake delay to be switched at F4 64
Emergency stop at change of direction off 128				

Setting the driving of the motor

Name of CVs / registers	CV-no.	Rg-no.	Input value (Default)	Remarks and Tips	
Starting voltage (Starting velocity)	2	47	0 ... 255 (LD-G-32.2: 5) (LD-W-32.2: 50)	= The voltage to be output to the motor at speed level 1. 0 = 0 Volt 255 = max. voltage	
Acceleration rate	3	44	0 ... 255 (LD-G-32.2 : 20) (LD-W-32.2: 16)	= Length of the delay before the switching to the next higher / lower speed level when the locomotive is accelerating / braking. The delay is calculated as follows: (value of CV 3) x 0,9 sec. / number of speed levels	
Braking rate	4	45	0 ... 255 (LD-G-32.2: 15) (LD-W-32.2: 5)		
Maximum voltage (maximum velocity)	5	46	0 ... 255 (0)	= The voltage to be output to the motor at the highest speed level. 2 = 0,8 % of the max. voltage 255 = maximum voltage	
Motor frequency (LD-W-32.2)	9	48	0, 1 (0)	=Frequency controlling the motor	
				480 Hz	0
				60 Hz	0
Tip: In case that the locomotive's driving characteristics are not satisfactory with the standard setting of 480 Hz, the motor frequency of 60 Hz should be chosen.					

Setting the driving of the motor (continuation)

Name CV / Register	CV-Nr.	Rg.-Nr.	Eingabewert (Defaultwert)	Erläuterungen und Hinweise
Braking performance with d.c. voltage	27	49	0, 32, 64,96 (0)	No braking with d.c. voltage 0
				Braking with negative d.c. voltage 32
				Braking with positive d.c. voltage 64
<p>Tip: It is standard to switch over into analogue mode when applying a d.c. voltage at the rails. In case that the decoder is run in a layout with a braking route based on applying a d.c. voltage (e.g. Märklin**-braking route), the analogue recognition has to be deactivated (in CV 29) to ensure that the locomotive reacts as expected on the braking route.</p> <p>The setting of the negative or positive d.c. voltage is related to the right rail, as seen in the locomotive's direction of motion.</p>				
Starting-kick	65	62	0 ... 255 (LD-G-32.2: 0) (LD-W-32.2: 55)	= short-time increase of motor voltage while starting to clear the breakaway torque
<p>Example: CV 65 = 6 → The motor voltage while starting is equivalent to the voltage applied in operation at speed level 6 (of 255). It is reduced immediately to the actually set speed level with the braking rate defined in CV 4. Thus, when altering the value for CV 4 it may be necessary to alter CV 65, too.</p>				
Alternative velocity characteristic (only with mode 28 speed levels)	68 . . 95	68 . . 95	0 ... 255	= velocity table for the alternative velocity characteristic. Any motor voltage can be assigned to all of the 28 speed levels. 0 = voltage of "0" 255 = maximum voltage

Setting the load control (LD-G-32.2 only)

Name of CVs / registers	CV-no.	Rg-no.	Input value (Default)	Remarks and Tips
Parameter of load control KP	50	23	0 ... 255 (90)	= Proportional component of the load control.
The parameter KP defines the basic speed. A too small value → locomotive too slow. A too high value → heavy shuttering of the locomotive.				
Parameter of load control KI	51	24	0 ... 255 (70)	= Integral component of the load control.
The parameter KI provides the fine tuning of the load control. The value has to be adjusted in very small steps. A too high value → heavy shuttering of the locomotive.				
Parameter of load control KD	52	25	0 ... 255 (40)	= Differential component of the load control.
The parameter KD retards the transforming of the load control. A too small value → shuttering of the locomotive. A too high value → rocking of the locomotive.				
Optimising the load control	124	60	1...15 (4)	To adjust the load control to the individual motor voltage
The value for CV 124 has to be altered when the velocity does not increase with the high speed levels. Alter the value for CV 124 step by step until the highest velocity has just been reached at the highest speed level.				

Optimising the CV-settings

Above all, the driving characteristics can be influenced by setting the CV 2 (starting voltage) and CV 5 (maximum voltage) and for the decoders for d.c.motors (LD-G-32.2), in addition, by setting the CV 124 (optimizing the load control) and the CV 50 to 52 (parameters of the load control).

Make the setting for the load controlled decoder LD-G-32.2 in the following order, as far as required:

1. CV 124
2. CV 50 to 52
3. CV 2 and CV 5

To adjust the parameters for the load control (CV 50 to 52) the following procedure is recommended:

If the locomotive is shuttering: → Increase the value for CV 52 (KD) in 5-steps. If this does not lead to an improvement of the driving characteristics, set the value of CV 52 back to factory setting (default value). Then decrease the value for CV 50 (KP) in 5-steps and for CV 51 (KI) in 2-steps.

If the locomotive does not have enough power and e.g. gets very slow on the way uphill: → Increase the value for CV 51 (KI) in 2-steps, until the locomotive starts to shutter. Then increase the value for CV 52 (KD) in 5-steps. If this does not lead to an improvement or the locomotive starts to shutter immediately after increasing CV 51, set the values for CV 51 and CV 52 back to factory setting (default value) and increase the value for CV 50 (KP) in 5-steps.

If the locomotive is rocking: → Decrease the value for CV 52 in 5-steps.

Assignment of the outputs to the function keys F0 to F12

Name of CVs / registers	CV-no.	Rg-no.	Input value (Default)	Remarks and Tips
F0 forward on	33	08	0 ... 3 (1)	AUX1 1
F0 backward on	34	09	0 ... 3 (2)	AUX2 2
F1	35	10	0 ... 3 (4)	AUX3 4
F2	36	11	0 ... 3 (0)	
...	
F12	46	21	0 ... 3 (0)	

Factory settings: AUX1 to be switched with F0, switched on at forward motion. AUX2 to be switched with F0, switched on at backward motion.

Example: AUX2 to be switched with F5 → CV 39 = 2

Example: AUX1 and AUX2 to be switched with F6 → CV 40 = 3 (= 1+2)

Effects of the outputs

Name of CVs / registers	CV-no.	Rg-no.	Input value (Default)	Remarks and Tips
AUX1	53	26	0 ... 255 (0)	Independent of direction 0
AUX2	54	27	0 ... 255 (0)	AUX off at backw. motion 1
AUX3	55	28	0 ... 255 (0)	AUX off at forward motion 2
				Flashing inverted 8
				Keying ratio of the flash lights :
				Lighting off 0
				16, 32, 48, 64, 80, 96, 112
				Regular flashing 128
				144, 160, 176, 192, 208, 224
				Permanent light 240

Example: Regular flashing at AUX1 and lighting off at forward motion
→ CV 53 = 130 (= 128 + 2)

Tip: The keying ratio for the flash lights determines the phase length of the on-/off states of the lighting.

Settings for the flash lights

Name of CVs / registers	CV-no.	Rg-no.	Input value (Default)	Remarks and Tips
Flashing frequency of the lighting	112	38	10 ... 255 (200)	Settings common for all lighting
				10 = lowest frequency
				255 = highest frequency
Examples for the flashing frequency: CV 112 = 10 → 0,125 Hz / CV 112 = 200 → 0,5 Hz CV 112 = 230 → 1 Hz / CV 112 = 255 → 2,5 Hz				

Dimming of the outputs

Name of CVs / registers	CV-no.	Rg-no.	Input value (Default)	Remarks and Tips
AUX1, AUX2	62	35	1...255 (255)	= Reduction of the voltage applied to the output. "1" = lowest voltage, "255" = maximum voltage
AUX3	63	36	1...15 (15)	
It is possible to choose a value between 0 and 15 for any of the outputs. For the outputs with an odd number the value is set directly, for the outputs with an even number the input value has to be multiplied by 16. Example: For AUX1 value "14" and for AUX2 value "2" → input value: 46 (=14 + 2x16)				

Dimming of the outputs depending on the speed level

Name of CVs / registers	CV-no.	Rg-no.	Input value (Default)	Remarks and Tips
Internal speed level for CV 116	113	39	1 ... 126 (16)	= speed level, from which the outputs defined in CV 116 are dimmed with the settings in CV 118 and 119 (instead of settings in CV 62 and 63).
Outputs dimmed depending on the speed level	116	43	0 ... 15 (0)	AUX1 1
				AUX2 2
				AUX3 4
Dimming depending on the speed level			= reduction of the voltage at the output	
AUX1, AUX2	118	54	1...255 (255)	"1" = lowest voltage
AUX3	119	55	1...15 (15)	"255" = maximum voltage
Values are applied to the outputs determined in CV 116 and starting from a speed level determined in CV 113 only.				
It is possible to choose a value between 0 and 15 for any of the outputs. For the outputs with an odd number the value is set directly, for the outputs with an even number the input value has to be multiplied by 16.				
Example:				
For AUX1 value "14" and for AUX2 value "2" → input value: 46 (=14 + 2x16)				

Shunting light

Name of CVs / registers	CV-no.	Rg-no.	Input value (Default)	Remarks and Tips
Shunting light	115	42	0 ... 255 (0)	for AUX1 1
				for AUX2 2
				for AUX3 4
				to be switched with F3 64
				to be switched with F4 128
Example: For AUX2 and AUX 3 shunting light, to be switched with F4: → input value: 134 (= 2 + 4 + 128)				

9. Check list for troubleshooting

- Parts are getting very hot and/or start to smoke.



Disconnect the system from the mains immediately!

Possible cause: one or more connections are soldered incorrectly.
→ Check the connections.

Possible cause: Short circuit between the decoder or accessories connected to the retrain conductor for all functions and metal parts of the locomotive or the rails. → Check the connections. A short circuit can result in irreparable damage.

Problems with the driving characteristics

- After programming the decoder the locomotive does not run or runs badly.

Possible cause: The set values for the CV are inconsistent.
→ Perform a decoder reset and program the decoder anew.

- In digital mode the locomotive suddenly runs very fast.

Possible cause: Interfering signals from the layout have switched the decoder to analogue mode. → As the origin of the interfering signals often cannot be found, it is advisable to switch off the automatic recognition of the analogue mode during digital operation.

- The CV values cannot be read out by RailCom.

Possible cause: RailCom is switched off. → Alter the value of CV 29 (add "8" to the input value).

Problems in analogue mode

- The locomotive does not run in analogue mode, the decoder does not work.

Possible cause: The analogue mode is switched off. → Alter the value for CV 29.

Problems with switching of the functions

- An accessory / a light does not react to switching commands.
Possible cause: The accessory is defective or incorrectly connected.
→ Check the accessory / the connections.
Possible cause: The output is defective (e.g. due to overload or short circuit). → Send in the decoder for check / repair (with costs).
- The lighting goes on and off when the speed levels are turned up or the lighting cannot be switched on or off.
Possible cause: The speed mode of the decoder and the digital control unit do not correspond. Example: The central is set to the mode 28 speed levels, but the decoder to the mode 14 speed levels. → Change the speed mode at the central and / or at the decoder.

Hotline: If problems with your decoder occur, our hotline is pleased to help you (mail address on the last page).

Repairs: You can send in a defective decoder for repair (address on the last page). In case of guarantee the repair is free of charge for you. With damages not covered by guarantee, the maximum fee for the repair is 50 % of the sales price according to our valid price list. We reserve the right to reject the repairing of a decoder when the repair is impossible for technical or economic reasons.

Please do not send in decoders for repair charged to us. In case of warranty we will reimburse the forwarding expenses up to the flat rate we charge according to our valid price list for the delivery of the product. With repairs not covered by guarantee you have to bear the expenses for sending back and forth.

10. Guarantee bond

For this product we issue voluntarily a guarantee of 2 years from the date of purchase by the first customer, but in maximum 3 years after the end of series production. The first customer is the consumer first purchasing the product from us, a dealer or another natural or juristic person reselling or mounting the product on the basis of self-employment. The guarantee exists supplementary to the legal warranty of merchantability due to the consumer by the seller.

The warranty includes the free correction of faults which can be proved to be due to material failure or factory flaw. With kits we guarantee the completeness and quality of the components as well as the function of the parts according to the parameters in not mounted state. We guarantee the adherence to the technical specifications when the kit has been assembled and the ready-built circuit connected according to the manual and when start and mode of operation follow the instructions.

We retain the right to repair, make improvements, to deliver spares or to return the purchase price. Other claims are excluded. Claims for secondary damages or product liability consist only according to legal requirements.

Condition for this guarantee to be valid, is the adherence to the manual. In addition, the guarantee claim is excluded in the following cases:

- if arbitrary changes in the circuit are made,
- if repair attempts have failed with a ready-built module or device,
- if damaged by other persons,
- if damaged by faulty operation or by careless use or abuse.

11. EU declaration of conformity

 This product conforms with the EC-directives mentioned below and is therefore CE certified.

2004/108/EG on electromagnetic. Underlying standards: EN 55014-1 and EN 61000-6-3. To guarantee the electromagnetic tolerance in operation you must take the following precautions:

- Connect the transformer only to an approved mains socket installed by an authorised electrician.
- Make no changes to the original parts and accurately follow the instructions, connection diagrams and PCB layout included with this manual.
- Use only original spare parts for repairs.

2011/65/EG on the restriction of the use of certain hazardous substances in electrical and electronic equipment (ROHS). Underlying standard: EN 50581.

12. Declarations conforming to the WEEE directive



This product conforms with the EC-directive 2012/19/EG on waste electrical and electronic equipment (WEEE).

Don't dispose of this product in the house refuse, bring it to the next recycling bay.

Information and tips:

<http://www.tams-online.de>

Warranty and service:

Tams Elektronik GmbH

Fuhrberger Straße 4

DE-30625 Hannover

fon: +49 (0)511 / 55 60 60

fax: +49 (0)511 / 55 61 61

e-mail: modellbahn@tams-online.de

